



# AUTOMOTIVE LEVEL-2



**CLASS X**  
Students Handbook



**CENTRAL BOARD OF SECONDARY EDUCATION**

Shiksha Kendra, 2, Community Centre, Preet Vihar, Delhi-110301





# Automotive echnology Level - 2

**Students Handbook**

**CLASS**

**X**



**CENTRAL BOARD OF SECONDARY EDUCATION**

Shiksha Kendra, 2, Community Centre, Preet Vihar, Delhi-110301

## Automotive Level - 2 Students Handbook, Class X

**Price:** ₹

**First Edition:** June 2015, CBSE

**Copies:**

**Paper Used:** 80 gsm CBSE Water Mark White Maplitho

**“This book or part thereof may not be reproduced by any person or agency in any manner.”**



**Published By** : The Secretary, Central Board of Secondary Education,  
Shiksha Kendra, 2, Community Centre, Preet Vihar, Delhi-110301

**Design & Layout** : Multi Graphics, 8A/101, WEA Karol Bagh, New Delhi-110005  
Phone: 011 - 25783846

**Printed By** :

# भारत का संविधान

## उद्देशिका

हम, भारत के लोग, भारत को एक सम्पूर्ण<sup>1</sup> प्रभुत्व-संपन्न समाजवादी पंथनिरपेक्ष लोकतंत्रात्मक गणराज्य बनाने के लिए, तथा उसके समस्त नागरिकों को:

सामाजिक, आर्थिक और राजनैतिक न्याय,  
विचार, अभिव्यक्ति, विश्वास, धर्म

और उपासना की स्वतंत्रता,  
प्रतिष्ठा और अवसर की समता

प्राप्त कराने के लिए

तथा उन सब में व्यक्ति की गरिमा

<sup>2</sup>और राष्ट्र की एकता और अखंडता

सुनिश्चित करने वाली बंधुता बढ़ाने के लिए

दृढ़संकल्प होकर अपनी इस संविधान सभा में आज तारीख 26 नवम्बर, 1949 ई० को एतद्वारा इस संविधान को अंगीकृत, अधिनियमित और आत्मार्पित करते हैं।

1. संविधान ( बयलीसवां संशोधन ) अधिनियम, 1976 की धारा 2 द्वारा ( 3.1.1977 ) से “प्रभुत्व-संपन्न लोकतंत्रात्मक गणराज्य” के स्थान पर प्रतिस्थापित।
2. संविधान ( बयलीसवां संशोधन ) अधिनियम, 1976 की धारा 2 द्वारा ( 3.1.1977 ) से “राष्ट्र की एकता” के स्थान पर प्रतिस्थापित।

## भाग 4 क

### मूल कर्तव्य

51 क. मूल कर्तव्य - भारत के प्रत्येक नागरिक का यह कर्तव्य होगा कि वह -

- (क) संविधान का पालन करे और उसके आदर्शों, संस्थाओं, राष्ट्रध्वज और राष्ट्रगान का आदर करे;
- (ख) स्वतंत्रता के लिए हमारे राष्ट्रीय आंदोलन को प्रेरित करने वाले उच्च आदर्शों को हृदय में संजोए रखे और उनका पालन करे;
- (ग) भारत की प्रभुता, एकता और अखंडता की रक्षा करे और उसे अक्षुण्ण रखे;
- (घ) देश की रक्षा करे और आह्वान किए जाने पर राष्ट्र की सेवा करे;
- (ङ) भारत के सभी लोगों में समरसता और समान भ्रातृत्व की भावना का निर्माण करे जो धर्म, भाषा और प्रदेश या वर्ग पर आधारित सभी भेदभाव से परे हों, ऐसी प्रथाओं का त्याग करे जो स्त्रियों के सम्मान के विरुद्ध हैं;
- (च) हमारी सामासिक संस्कृति की गौरवशाली परंपरा का महत्त्व समझे और उसका परिरक्षण करे;
- (छ) प्राकृतिक पर्यावरण की जिसके अंतर्गत वन, झील, नदी, और वन्य जीव हैं, रक्षा करे और उसका संवर्धन करे तथा प्राणी मात्र के प्रति दयाभाव रखे;
- (ज) वैज्ञानिक दृष्टिकोण, मानववाद और ज्ञानार्जन तथा सुधार की भावना का विकास करे;
- (झ) सार्वजनिक संपत्ति को सुरक्षित रखे और हिंसा से दूर रहे;
- (ञ) व्यक्तिगत और सामूहिक गतिविधियों के सभी क्षेत्रों में उत्कर्ष की ओर बढ़ने का सतत प्रयास करे जिससे राष्ट्र निरंतर बढ़ते हुए प्रयत्न और उपलब्धि की नई उंचाइयों को छू ले;
- <sup>1</sup>(ट) यदि माता-पिता या संरक्षक है, छह वर्ष से चौदह वर्ष तक की आयु वाले अपने, यथास्थिति, बालक या प्रतिपाल्य के लिये शिक्षा के अवसर प्रदान करे।

1. संविधान ( छयासीवां संशोधन ) अधिनियम, 2002 की धारा 4 द्वारा प्रतिस्थापित।

# THE CONSTITUTION OF INDIA

## PREAMBLE

**WE, THE PEOPLE OF INDIA**, having solemnly resolved to constitute India into a **'SOVEREIGN SOCIALIST SECULAR DEMOCRATIC REPUBLIC** and to secure to all its citizens :

**JUSTICE**, social, economic and political;

**LIBERTY** of thought, expression, belief, faith and worship;

**EQUALITY** of status and of opportunity; and to promote among them all

**FRATERNITY** assuring the dignity of the individual and the<sup>2</sup> unity and integrity of the Nation;

**IN OUR CONSTITUENT ASSEMBLY** this twenty-sixth day of November, 1949, do **HEREBY ADOPT, ENACT AND GIVE TO OURSELVES THIS CONSTITUTION.**

- 
1. Subs, by the Constitution (Forty-Second Amendment) Act. 1976, sec. 2, for "Sovereign Democratic Republic" (w.e.f. 3.1.1977)
  2. Subs, by the Constitution (Forty-Second Amendment) Act. 1976, sec. 2, for "unity of the Nation" (w.e.f. 3.1.1977)
- 

# THE CONSTITUTION OF INDIA

## Chapter IV A

### FUNDAMENTAL DUTIES

#### ARTICLE 51A

**Fundamental Duties** - It shall be the duty of every citizen of India-

- (a) to abide by the Constitution and respect its ideals and institutions, the National Flag and the National Anthem;
- (b) to cherish and follow the noble ideals which inspired our national struggle for freedom;
- (c) to uphold and protect the sovereignty, unity and integrity of India;
- (d) to defend the country and render national service when called upon to do so;
- (e) to promote harmony and the spirit of common brotherhood amongst all the people of India transcending religious, linguistic and regional or sectional diversities; to renounce practices derogatory to the dignity of women;
- (f) to value and preserve the rich heritage of our composite culture;
- (g) to protect and improve the natural environment including forests, lakes, rivers, wild life and to have compassion for living creatures;
- (h) to develop the scientific temper, humanism and the spirit of inquiry and reform;
- (i) to safeguard public property and to abjure violence;
- (j) to strive towards excellence in all spheres of individual and collective activity so that the nation constantly rises to higher levels of endeavour and achievement;
- <sup>1</sup>(k) to provide opportunities for education to his/her child or, as the case may be, ward between age of 6 and 14 years.

- 
1. Subs. by the Constitution (Eighty - Sixth Amendment) Act, 2002

# *Preface*



# Acknowledgements

## Advisors

1. Dr. Satbir Bedi, IAS, Chairperson, CBSE
2. Prof. R.B. Shivgunde, Joint Director, PSSCIVE, Bhopal
3. Sh. M.V.V. Prasada Rao, Director (Voc & Edusat), CBSE

## Content Developed By

1. PSSCIVE, Bhopal

## Editing & Coordination

1. Dr. Biswajit Saha, Additional Director (Voc), CBSE





# Contents

## UNIT - 1

<b>Automobile and its Components</b>	<b>1</b>
<b>Session 1</b> : Chassis	1
<b>Session 2</b> : Body or Superstructure	7
<b>Session 3</b> : Engine	9
<b>Session 4</b> : Lubrication System	15
<b>Session 5</b> : Cooling System	19
<b>Session 6</b> : Fuel Supply System	23
<b>Session 7</b> : Transmission System	25
<b>Session 8</b> : Front Axle	34
<b>Session 9</b> : Steering System	37
<b>Session 10</b> : Rear Axle	40
<b>Session 11</b> : Suspension System	42
<b>Session 12</b> : Wheel and Tyres	46
<b>Session 13</b> : Brakes	48
<b>Session 14</b> : Electrical and Electronics System	50
<b>Suggested Reading</b>	60

## UNIT - 2

<b>Tools</b>	<b>62</b>
<b>Session 1</b> : Hand Tool	62
<b>Session 2</b> : Measuring Tools	70
<b>Session 3</b> : Electrical Tools	73
<b>Session 4</b> : Special Tools	75
<b>Session 5</b> : Service Workshop Equipment	77
<b>Suggested Reading</b>	80

## UNIT - 3

<b>Vehicle Servicing</b>	<b>82</b>
<b>Session 1</b> : Washing of a Vehicle	82



<b>Session 2</b> :	Changing of Oil and Oil Filter	86
<b>Session 3</b> :	Changing of Air Filter	90
<b>Session 4</b> :	Changing of Fuel Filter	93
<b>Session 5</b> :	Changing of Coolant	96
<b>Suggested Reading</b>		98

## UNIT - 4

<b>Customer Sales Care</b>		<b>99</b>
<b>Session 1</b> :	Customer Service	99
<b>Suggested Reading</b>		103

## UNIT - 5

<b>Innovation and Development</b>		<b>104</b>
<b>Session 1</b> :	Innovation and Development	104
<b>Suggested Reading</b>		113



# Unit-1

## Automobile and Its Components

### Introduction

As you know that the growth in the automobile sector is progressing in our country. New developments are taking place day by day. In level-1, you have gone through the basic concepts of an automobile and its component. You learnt the role of each component in an automobile. In this unit we will be discussing the details of each component. It will help us in achieving a better understanding. These important components will be Chassis Frame, Body, Engine, Lubrication System, Cooling System, Fuel supply system, Transmission system Front and Rear Axle Steering System, Suspension System, Wheels and Tyre, Brakes, Electrical & Electronic Systems. As we know that these all are very important component of automobile. A vehicle can not be complete without them.

In this Unit, you will develop an understanding of the components of Chassis Frame, Body, Engine, Lubrication System, Cooling System, Fuel supply system, Transmission system Front and Rear Axle Steering System, Suspension System, Wheels and Tyre, Brakes, Electrical & Electronic Systems of an automobile vehicle.

### SESSION - 1: CHASSIS

#### Relevant Knowledge

You have studied the definition of chassis, various major components mounted on a chassis frame and the functions of the chassis frame in the previous level. We can say that chassis is the under part of a motor vehicle, consisting of the frame (on which the body is mounted) with the wheels and machinery. In this chapter you are going to learn more details about the chassis.



Fig: Chasis

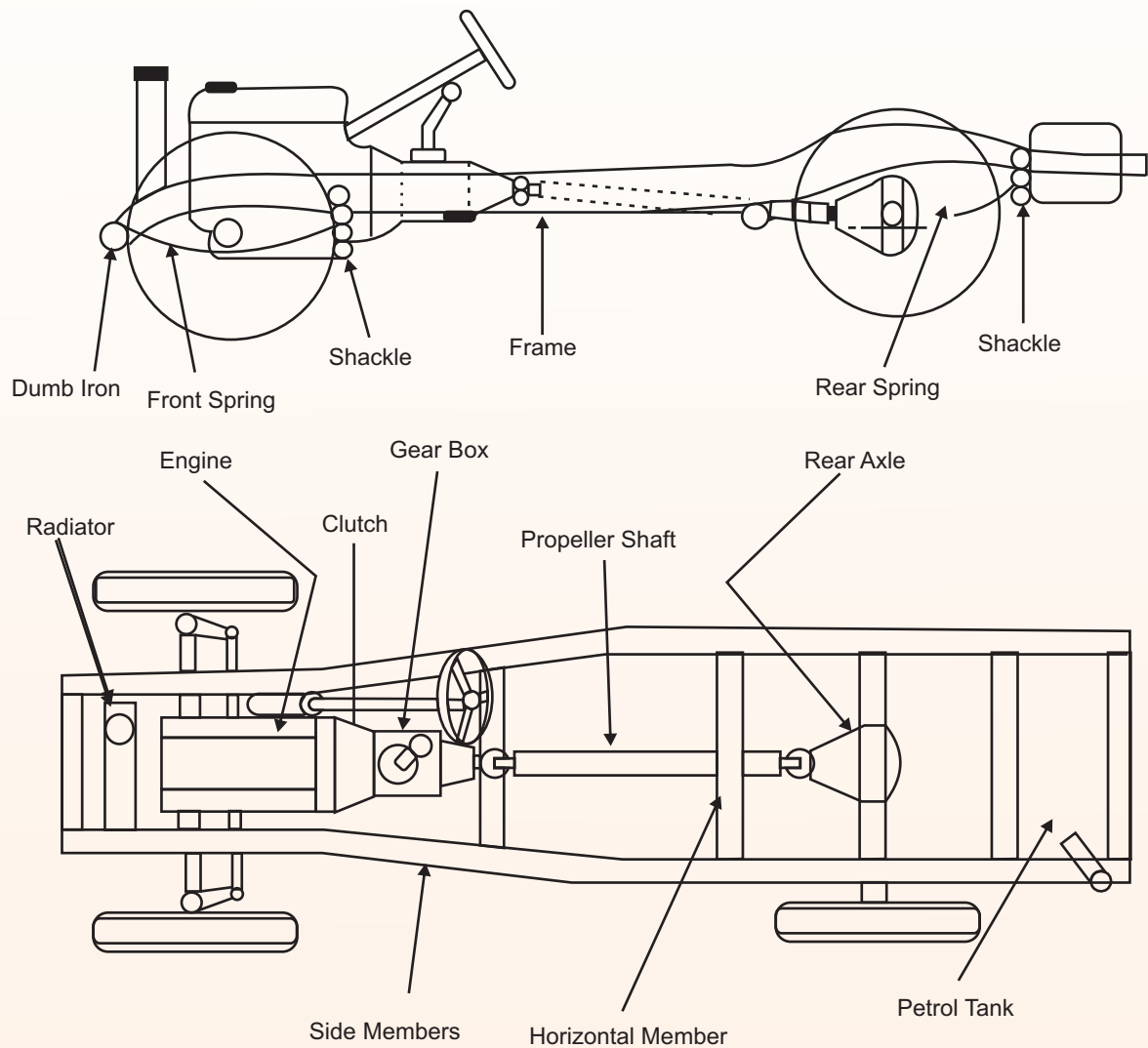


Fig: Chassis

## Classification of Chassis

According to the fitting of engine the classification of Chassis is as follows:

1. Full forward
2. Semi-forward
3. Bus chassis
4. Engine in front
5. Engine at centre

**Full forward chassis** is one in which the engine is fitted outside the driver cabin or seat like in cars and old Tata-trucks. In this type of arrangement, the driver seat is far from the front wheels and he is not able to see just in front of the vehicle.

**In Semi-forward chassis**, half portion of the engine is in the driver's cabin and the remaining

half is outside the cabin like in standard, Bedford pick. It provides better visibility of road to the driver.

In bus chassis, the whole engine is fitted in the driver cabin. It provides an increased floor space in the vehicle. The driver seat is just above the front wheel and he can see the full front road right from the front wheels.

In most of the vehicles, the engine is fitted in front portion of the chassis. The drive is given to the front wheels only in matador vehicles.

The engine may also be fitted at the back portion of the chassis, like in Tata and Ashok Leyland buses. This arrangement does not require long propeller shaft. Gearbox and Differential are combined in one unit.

The engine may also be fitted at the centre of the chassis. This arrangement provides full space of chassis floor for use.

According to the number of wheels fitted in the vehicles and the number of driving wheels, the vehicle chassis's are of the following types:

- (a) **4 X 2 drive chassis vehicle:** consists of 4 wheels out of which 2 wheels are the driving wheels.
- (b) **4 X 4 drive chassis vehicle:** consists of 4 wheels and all of them are the driving wheels.
- (c) **6 X 2 drive chassis vehicle:** consists of 6 wheels out of which 2 wheels are the driving wheels.
- (d) **6 X 4 drive chassis vehicle:** consists of 6 wheels out of which 4 wheels are the driving wheels.

### Classification of Chassis Frame

You have already studied that there are two types of chassis frames:

1. Conventional Chassis frame.
2. Integral Chassis frame.

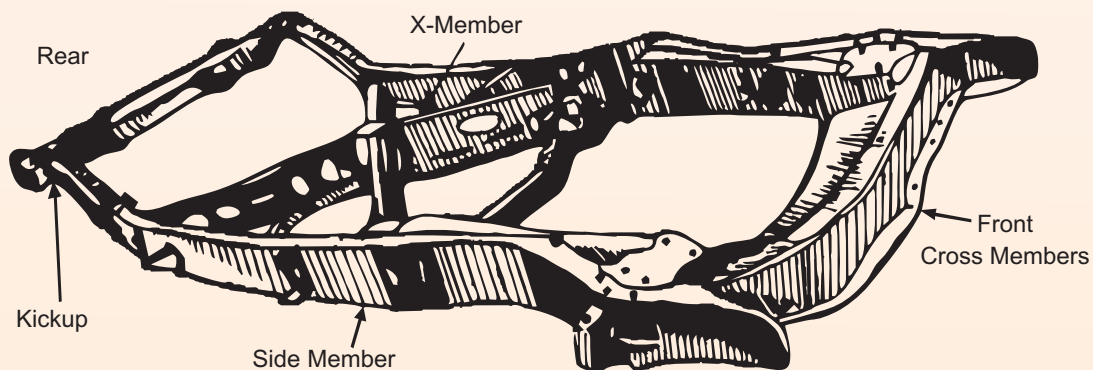


Fig: X-member type Jeep Chassis Frame

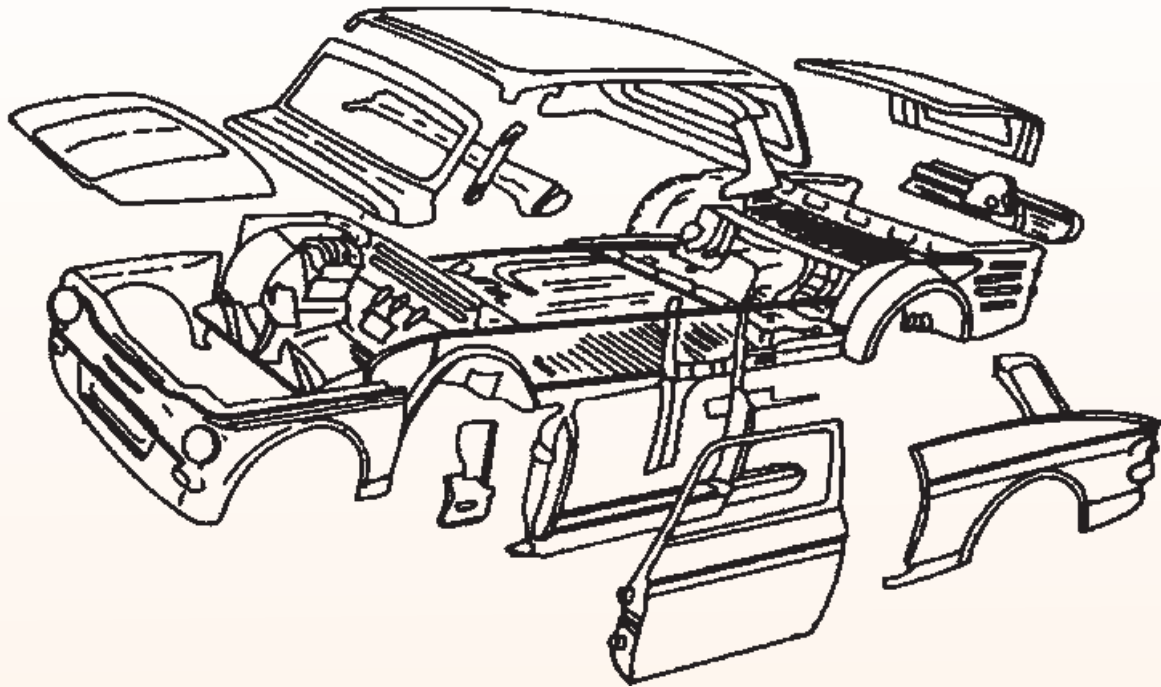


Fig: Integral or unit Frame and Body Construction

### Advantages and Disadvantages of Frameless or Integral Frame Chassis over conventional type Chassis frame.

#### Advantages

- ❖ Cost is less, as the body floor works as long and cross members.
- ❖ Deadweight of vehicle is less, as body floor works as a chassis and extra cross members are eliminated.
- ❖ Due to elimination of frame, the centre of gravity of the vehicle is lowered, which gives more stability, specially for fast moving vehicles. As stated above, the main floor works as a chassis. As such floor is pressed to form small sections and channels are welded to give it extra strength. A standard Car manufactured in India is equipped with this type of frameless construction.

#### Disadvantages

- ❖ The only disadvantage of having an integral frame chassis is, that, in case of an accident, it becomes difficult to repair, set it right and properly align the same.

#### The frames are made of following steel sections:

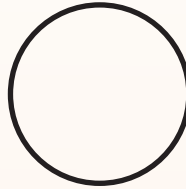
- ❖ Channel Section



•• Box Section



•• Tubular Section



**Channel Section** is used in long member and box section in short members. **Tubular section** is used now-a-days in three-wheelers, scooters and matadors, pick-ups frames.

### Loads on the Chassis frame

The frames should be strong enough to bear load, sudden brakes and accidents. Following loads act on the chassis frame.

- Weight of the vehicle and the passengers.
- Vertical loads when the vehicle comes across a bump or hollow.
- Engine torque.
- Inertia loads due to brake application.
- Sudden impact loads during a collision.
- Loads for longer periods e.g., cornering force while taking a turn.

### Exercise: Assignment

1. List the types of chassis:

S.No.	Types of Chassis

2. Prepare a poster showing chassis used in a vehicle:



3. A. Fill in the blanks:

- a) Chassis is used for \_\_\_\_\_.
- b) Channel section is used \_\_\_\_\_.
- c) Tubular section is used in \_\_\_\_\_, \_\_\_\_\_ model.
- d) In bus chassis, the whole engine is fitted in the \_\_\_\_\_ cabin.
- e) Chassis is the \_\_\_\_\_ part of a \_\_\_\_\_ vehicle consisting of the frame with the \_\_\_\_\_ and machinery.

B. Tick the correct answer:

- 1. Channel section is made of
  - a) Iron
  - b) Wood
  - c) Steel
  - d) Aluminum
- 2. A chassis is used for
  - a) Carrying the bolt
  - b) Opening the load
  - c) Fixing the auto body
  - d) Folding the nut
- 3. Chassis is made of
  - a) Wood
  - b) Oil
  - c) Metal
  - d) Plastic

**Checklist for Assessment Activity**

Use the following checklist to see if you've met all the requirements for chassis frame and automobile body.

**Part A**

- ❖ Share characteristics of chassis frame

**Part B**

Discuss in class the following:

- ❖ What is meaning of chassis?
- ❖ What are the different types of chassis frames used in automobiles?
- ❖ Classification of chassis.
- ❖ Section used in the chassis.
- ❖ Advantage of integral frame chassis over conventional chassis frame.

**Performance standards/criteria covered by this assessment**

Performance Standards	Yes	No
Able to explain importance of Chassis		
Able to identify general section used in chassis frame		



## SESSION - 2: BODY OR SUPERSTRUCTURE

### Relevant Knowledge

In the previous level you studied little about the type of body and their fixing methods with the chassis frame and the requirements of automobile body. Here you are going to learn about different the parts of the body or superstructure.

### Different parts of Automobile Body

1. **Body shell:** The body structural assemblies are joined into an integral shell by electric spot welding.
2. **Floor Assemble:** Generally, the floor of the body is assembled first and after that the pillars, rails and panels are welded in order to form the complete body.
3. **Doors:** Each door is provided with a check arm consisting of an articulated plate secured on a pillar and sliding into a slot in door. A rubber pad on check arm tip prevents the arm from sliding out of its slot, thus checking opening of the door. Door windows are held by fasteners.
4. **Windshield and Back window:** To improve visibility the windshield and back window are curved. They are also provided with weather strips and bright metal reveals.
5. **Body inner trimming:** The car body is lined with special paints, sound reducing and water proofing compounds as well as stuffing and covering materials. It is done for following two main purposes.
  - ❖ To reduce mechanical components vibrations
  - ❖ To improve car appearance and comfort.
6. **Seats:** The bench type front seat consists of a metal framing on which the stuffed, cloth and imitation leather upholstered seat back is fixed. A lever projecting laterally to the cushion disengages the slide catch for seat position adjustment. The cushion is just press fitted in the framing.

The rear seat is in two separate parts.

  - ❖ The back, fitted between the rear wheel boxes and resting against the luggage compartment partition.
  - ❖ The cushion, resting directly on floor and positioned by two rubber studs.
7. **Hood:** The hood is made in a single piece, hinged at the rear to cover the engine compartment. Around the edges of the engine compartment on which the hood rests when closed are fitted rubber bumper pins. The hood is kept closed by a locking catch.
8. **Deck lid:** The deck lid is opened and closed, with the help of a handle. To keep the lid closed, a catch is engaged in a striker. The luggage compartment opening edge is lined with rubber weather strips. In a well at bottom of luggage compartment, is the spare wheel.

9. **Bumpers:** The rear and front bumpers consist of a single bar provided with two ornaments. The rear bumper is secured by screws of the ornaments and by two side screws covered with chromium plated bosses. The front bumper is secured through the ornament stud screws and nut, in two brackets welded on body.

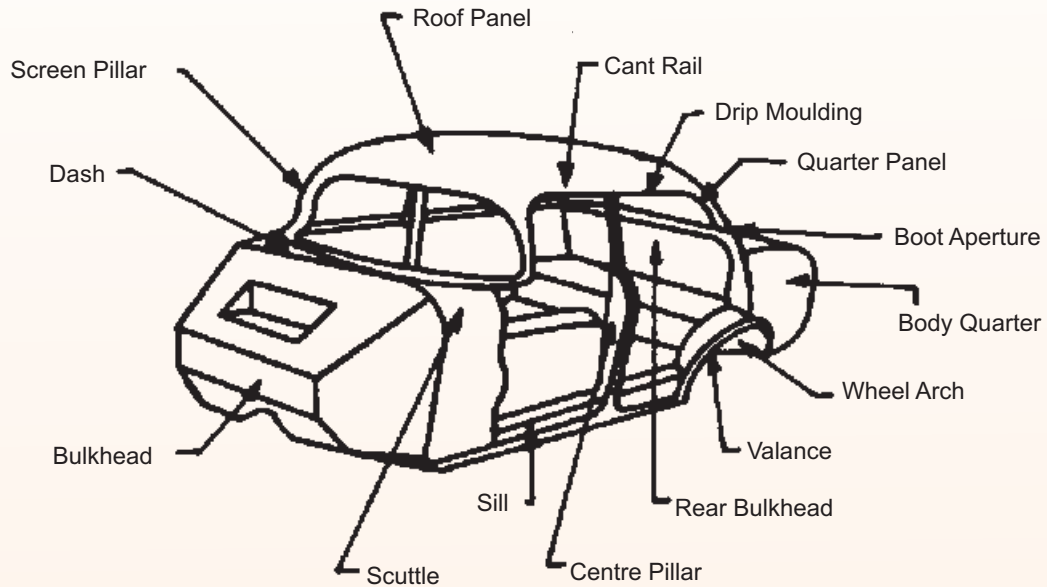


Fig: Various Parts of a Car Body

### Exercise: Assignment

1. List the different part of the vehicle body:

S.No.	Different parts of the vehicle body

2. Prepare a poster showing different parts of a body of a vehicle:

### 3. Fill in the blanks:

- a) Body is used for \_\_\_\_\_.
- b) Door windows are held by \_\_\_\_\_.
- c) The hood is made in a \_\_\_\_\_ piece.
- d) The rear and front bumpers consist of a \_\_\_\_\_ provided with two ornaments.

### Checklist for Assessment Activity

Use the following checklist to see if you've met all the requirements for pollution control.

#### Part A

- 2 Share importance of the body of a vehicle.

#### Part B

Discuss in class the following:

- 2 What is meaning of body in a vehicle?
- 2 What are the different components of the vehicle body.
- 2 Differentiate between hood and bumper.
- 2 Name two important components used in a vehicle body.
- 2 Write about the importance of windshield.

#### Performance standards/criteria covered by this assessment

Performance Standards	Yes	No
Able to explain importance of body		
Able to identify general components of a body		

## SESSION - 3: ENGINE

### Relevant Knowledge

In the previous level you studied about the definition of an IC engine, types of engine (SI Engine & CI Engine) and various components of an IC engine and their purposes.

We can say again that the engine or motor is a machine designed to convert energy into useful mechanical motion. Heat engines, including internal combustion engines and external combustion engines (such as steam engines) burn a fuel to create heat, which, is then used to create motion.

In this level you are going to learn about various classifications of automobile engines, different technical terms used in IC engine, etc.

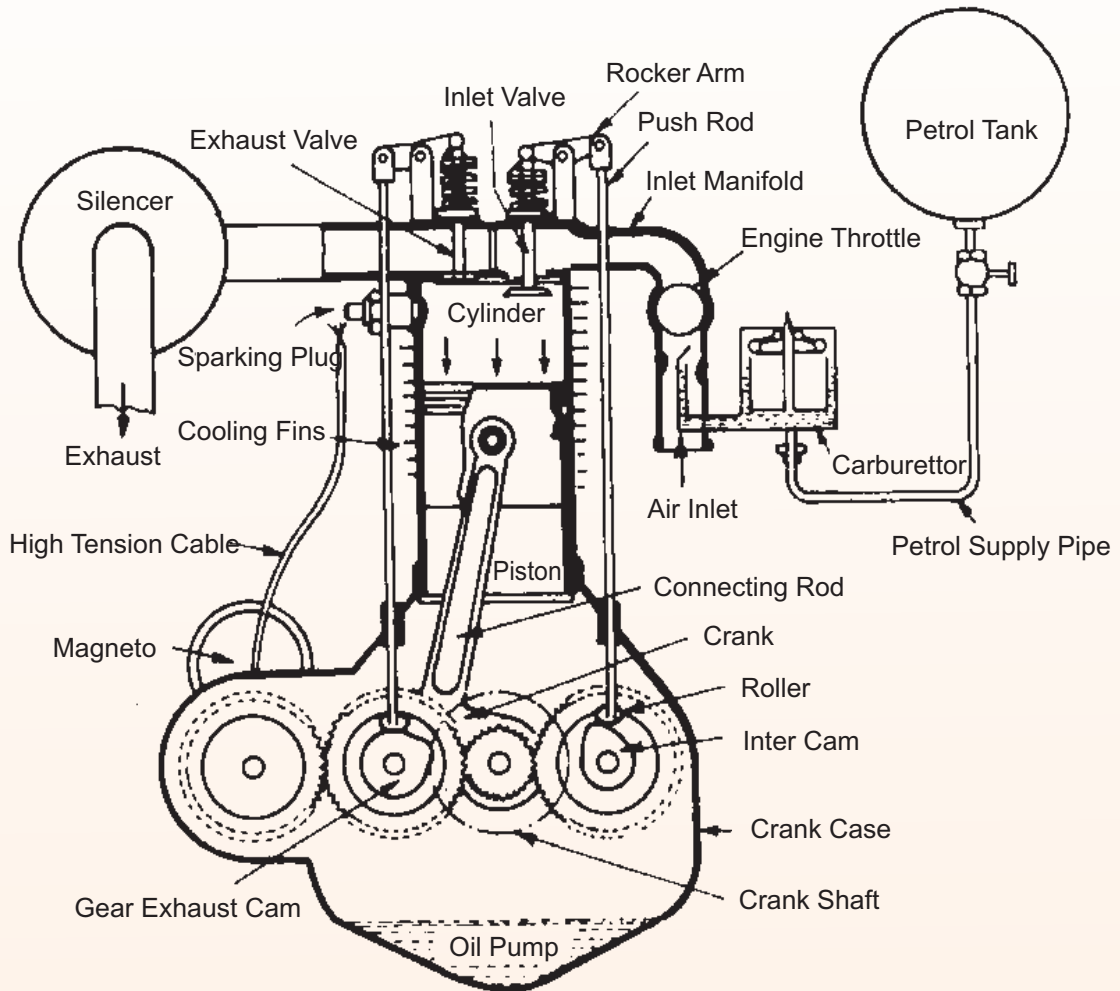


Fig: Stroke Petrol Engine

## Classification of Automobile Engines

The engines for the automotive use may be classified according to the following considerations:

### 1. Cycle of Operation

- Otto Cycle Engine
- Diesel Cycle Engine

### 2. No. of Strokes Per Cycle

- Two Stroke Engine
- Four Stroke Engine

### 3. Fuel Used

- Petrol Engine (or Gasoline Engine)
- Diesel Engine
- Gas Engine

#### 4. Types of Ignition

- Spark Ignition (SI) Engine
- Compression Ignition (CI) Engine

#### 5. No. of Cylinders

- Single-cylinder Engine
- Six-cylinder Engine
- Two-cylinder Engine
- Eight-cylinder Engine
- Three-cylinder Engine
- Twelve-cylinder Engine
- Four-cylinder Engine
- Sixteen-cylinder Engine

#### 6. Arrangement of Cylinders

- Inline Vertical Engine
- Opposed cylinder Engine
- Horizontal Engine
- Radial Engine
- V-type Engine

#### 7. Valve Arrangement Engine

- L-head Engine
- I-head Engine
- F-head Engine
- T-head Engine

#### 8. Type of Cooling

- Air-cooled Engine
- Water-cooled Engine

In addition to the above classifications, the internal combustion engines are classified on the following bases also:

#### 9. Speed

- Low Speed Engine
- High Speed Engine
- Medium Speed Engine

#### 10. Method of Fuel Injection

- Carburettor Engine



- Air Injection Engine
- Airless or Solid Injection Engine

### 11. Method of Governing

- Hit and miss governed Engine
- Qualitatively governed Engine
- Quantitatively governed Engine

### 12. Application

- Stationary Engine
- Marine Engine
- Automotive Engine
- Aircraft Engine
- Locomotive Engine

### 13. Special Type Engine

- Wankel Engine
- Automotive Gas Turbine

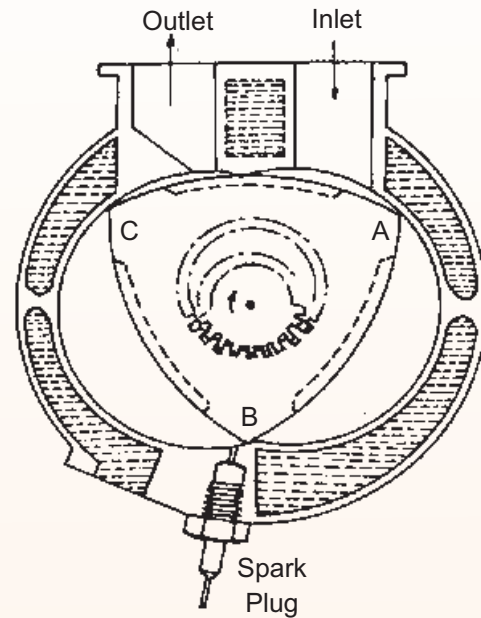


Fig: Wankel Rotary Engine

## Technical Terms Used In Engine

A number of basic terms are used to describe and compare engines. A few commonly used terms are described here.

- **Top Dead Centre (T.D.C):** This refers to the position of the crankshaft when the piston is in its top most position i.e. the position closest to the cylinder head.
- **Bottom Dead Centre (B.D.C):** This refers to the position of the crankshaft when the piston is in its lowest position i.e. the position farthest from the cylinder head.
- **Bore:** Diameter of the engine cylinder is referred to as the bore.
- **Stroke:** Distance travelled by the piston in moving from T.D.C. to the B.D.C is called 'stroke'.
- **Clearance Volume:** The volume of cylinder (including the combustion chamber) above the piston when it is in the T.D.C. position is referred to as 'clearance volume' ( $V_c$ ).
- **Piston Displacement:** This is the volume swept by the piston in moving from T.D.C. to B.D.C. This is also called 'swept volume'. If 'd' is the cylinder bore and 'S' the stroke, the piston displacement,  $V_s$  is given by

$$V_s = \frac{\pi}{4} d^2 \cdot s$$

- **Engine Capacity:** This is the total piston displacement or **the Swept volume** of all the cylinders. If 'n' is the number of cylinders and  $V_s$  is the piston displacement, then 'engine displacement' or engine capacity  $V_d$ , is given by

$$V_d = V_s \cdot n$$

- **Compression Ratio:** This indicates the extent to which the charge in the engine is compressed. This is calculated as the ratio of the volume above the piston at B.D.C. to the volume above the piston at T.D.C. If 'y' is the compression ratio, then

$$y = \frac{V_s + V_c}{V_c}$$

For petrol engines, compression ratios are about 8 to 9.5 : 1, whereas for diesel engines, these vary from 16 to 22.

- **Power:** It is the work done in a given period of time. Doing the same amount of work in a lesser time would require more power.
- **Horse Power (H.P.):** This is the amount of energy required to do 4500kgm. of work in one minute.
- **Indicated Horse Power (I.H.P):** The power developed within the engine cylinders is called indicated horse power. This is calculated from the area of the engine indicator diagram.
- **Brake Horse Power (B.H.P):** This is the actual power delivered at the crankshaft. It is obtained by deducting various power losses in the engine from the indicated horse power.
- **Friction Horse Power (F.H.P):** This is the power lost due to friction present between different matching components.

$$F.H.P = I.H.P - B.H.P$$

- **Engine Torque:** It is the force of rotation acting about the crankshaft axis at any given instant of time. It is expressed in newton-metre (Nm).

Engine torque goes through the vehicle transmission system, to the road wheels and is responsible for rotation of the latter and hence for pulling of the vehicle.

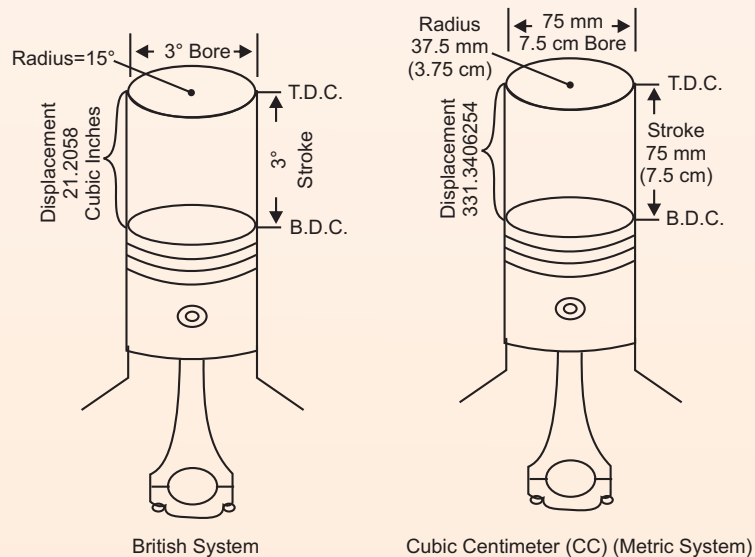


Fig: Engine Displacement

## Exercise: Assignment

1. List the components of an engine:

S.No.	Name of component

2. Prepare a poster showing engine used in automobiles:

3. Fill in the blanks:

- a) Full form of TDC is \_\_\_\_\_.
- b) BDC full form \_\_\_\_\_.
- c) Internal combustion engines \_\_\_\_\_ a fuel to create \_\_\_\_\_ which is then used to create motion.
- d) Engine torque goes \_\_\_\_\_ the vehicle transmission system.

### Checklist for Assessment Activity

Use the following checklist to see if you've met all the requirements for understanding of the engine.

#### Part A

- Share classification of engine used in a vehicle.

#### Part B

Discuss in class the following:

- Classification of engine
- Classification based on cylinder
- Capacity of an engine
- Name popular type of engine used in motor cycles
- Importance of an engine



## Performance standards/criteria covered by this assessment

Performance Standards	Yes	No
Able to explain importance of engines		
Able to classify the engine		

## SESSION 4: LUBRICATION SYSTEM

### Relevant Knowledge

In the previous level you studied about the object of lubrication in an automobile. In this level you are going to learn more about the lubrication system of an engine. We can say that the Lubrication system delivers oil to the moving parts of the engine to reduce friction and to assist in keeping the parts cool. The figure below shows the movement of oil to the different parts of an engine.

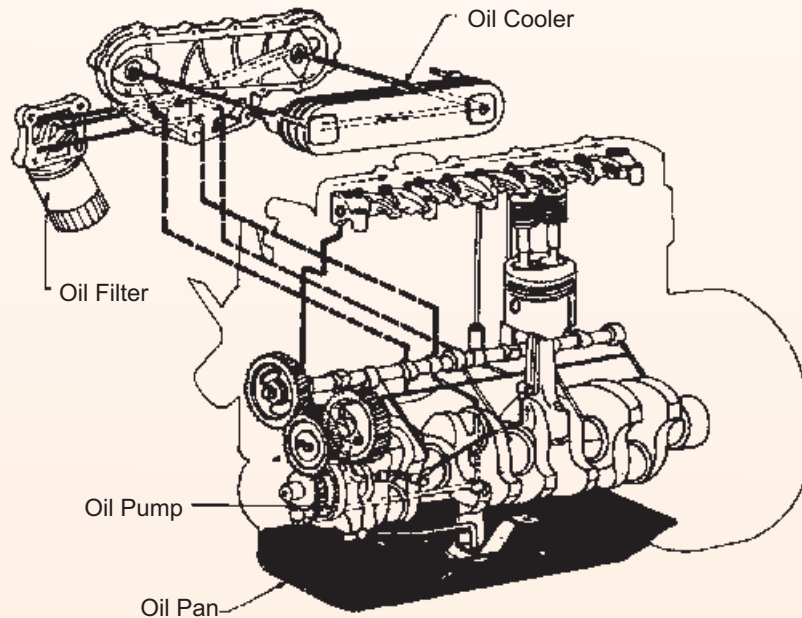


Fig: Lubrication System

### Automobile Engine Lubrication

The main parts of an automotive engine which require lubrication are:

- Main crankshaft bearings
- Big end bearings
- Gudgeon pin bearings
- Piston rings and cylinder walls
- Timing Gears
- Camshaft and camshaft bearings

## Properties of a good lubricant

As we understand that the lubricant is a very important component of an engine. We must know some of the properties. These properties are given here:

1. **Viscosity:** In simple language, Viscosity may be considered as the resistance of the lubricating oil to flow. It is this property alone, due to which, the bearing surfaces are kept apart, i.e. hydrodynamic lubrication is maintained.

The viscosity of the lubricating oil should be just sufficient to ensure hydrodynamic lubrication. A higher value than this would be of no use since it will involve higher power losses due to the increased oil resistance.

The viscosity of the lubricating oil, at the time of starting the engine, should be low otherwise the engine may not start. On the other hand with the engine running, the oil viscosity decreases due to increase of temperature, which is contrary to what is desirable, since at all operating temperatures, the viscosity should not fall below the minimum value required to maintain hydrodynamic lubrication. Therefore, the viscosity should ideally remain the same at all temperatures. Relative change of viscosity with temperature is called **viscosity index**. However, the viscosity of all the oils does vary with temperature and, therefore, the oil with minimum variation is preferred.

Viscosity is the most important property of lubricants and they are mostly selected on the basis of their viscosity and temperature coefficient of viscosity (viscosity index).

2. **Physical Stability:** The lubricating oil must be stable physically at the lowest and the highest temperatures encountered in practice. There should not be any separation of solids at the lower temperatures and at higher temperatures it should not vapourise beyond a certain limit.
3. **Chemical Stability:** At higher temperature the oil should remain chemically stable. There should not be any tendency for oxide formation, many of the oxidation products being sticky substances clog the lines and cause faulty piston rings and valve action.

The oil should also not decompose at high temperatures to form carbon. Carbon thus formed, lowers rings efficiency, thus reducing engine compression. The spark plugs and the valves also do not function efficiently due to sticking of carbon particles.

4. **Resistance against Corrosion:** The oil should not have any tendency to corrode the pipe lines, crank case and other engine parts with which it comes into contact.
5. **Pour Point:** The minimum temperature at which the oil will pour is called its pour point. Obviously, since the oil will not be able to flow below the pour point, it cannot be used below this temperature for lubrication. Thus, the pour point of the oil should be less than the lowest temperature encountered in the engine.

The pour point is the temperature at which a lubricant just ceases to flow when cooled under standard conditions. The lower the pour point, the better is the lubricant.

6. **Flash Point:** The flash point of the oil should be sufficiently high so as to avoid flashing of

oil vapours at the temperatures occurring in common use. A flash point higher than the minimum desired value will not serve any useful purpose.

Flash point of a lubricating oil is the minimum temperature at which it gives off sufficient vapour so as to form an explosive mixture with air. If the oil is heated further a stage will reach when it will begin to burn continuously on applying a flame to it. This temperature is called the fire point.

- Cleanliness:** The oil should be sufficiently clean and stable itself so that the crank case and oil lines are kept clean. Further it must contain agents, called detergents, which remove the impurities from the engine parts during oil circulation. These impurities may either be filtered out or removed with the change of oil at periodic intervals.

## Types of Lubricants

Depending on widely varying requirements of different parts, the automotive lubricants may be classified as below:

- On the basis of their state**
  - Solid lubricant such as graphite, soapstone, talc, mica, molybdenum disulphide.
  - Semi-solid lubricants such as greases e.g., aluminium paste.
  - Liquid lubricants such as mineral oil, vegetable oils, animal oils.
  - Emulsions such as oil in water.
- On the basis of their origin**
  - Natural lubricants such as mineral oils, vegetable oils, animals oils, graphite.
  - Synthetic lubricants such as refined petroleum oils, commercial grade oils, grease.
- On the Basis of Variation in Viscosity**
  - Mono-grade oils such as SAE 20, SAE 30, SAE 50 etc.
  - Multi-grade oils such as SAE 20W 40, SAE 15W 40 etc.
- On the basis of special preparation**
  - Blended lubricants such as blended by castor oil, palmitic acid, oleic acid.
  - Compounded lubricants such as compounded with polyglycols, fluorocarbons, silicones.

## Exercise: Assignment

- List the parts which require lubrication:

S.No.	Name of parts

2. Prepare a poster showing lubrication system:

3. A. Fill in the blanks:

- a) Lubrication system delivers oil to the moving parts of the engine to reduce friction.
- b) Viscosity of the lubricating \_\_\_\_\_ should be just sufficient to ensure \_\_\_\_\_ lubrication.
- c) At higher \_\_\_\_\_ the oil should remain \_\_\_\_\_ stable.
- d) Flash point of a \_\_\_\_\_ oil is the minimum \_\_\_\_\_ at which it gives off sufficient \_\_\_\_\_ so as to form an explosive mixture with air.

B. Tick the odd answer:

1. Natural lubricants are made of:

- a) Mineral oil
- b) Vegetable oil
- c) Animal oil
- d) Aluminium

2. A synthetic lubricant is made from

- a) Refined petroleum oils
- b) Commercial grade oil
- c) Grease
- d) Water

3. Lubrication is used for reducing

- a) Friction
- b) Cooling part
- c) Decrease in temperature
- d) Spare parts

### Checklist for Assessment Activity

Use the following checklist to see if you've met all the requirements for understanding the lubrication system.

#### Part A

- ❖ Share importance of the lubrication used in a vehicle.

#### Part B

Discuss in class the following:

- What is the meaning of lubricants?
- What are the different types of lubricant used in automobiles?
- Differentiate between different types of lubricants.
- Flash point and Pour point – explain.
- Importance of properties of lubricants.

#### Performance standards/criteria covered by this assessment

Performance Standards	Yes	No
Able to explain importance of lubrication		
Able to identify general lubricants		

## SESSION - 5: COOLING SYSTEM

### Relevant Knowledge

In the previous level you learnt about only the function of the cooling system and its necessity. In this level you will learn more about the cooling system.

All the heat produced by the combustion of fuel in the engine cylinders is not converted into useful power at the crankshaft. A typical distribution for the fuel energy is given below:

Useful work at the crank shaft	=	20 percent
Loss to the cylinders walls	=	35 percent
Loss in exhaust gases	=	35 percent
Loss in friction	=	10 percent

It is seen that the quantity of heat given to the cylinder walls is considerable and if this heat is not removed from the cylinders it would result in the preignition of the charge. In addition, the lubricant would also burn away, thereby, causing the seizing of piston. Excess heating will also damage the cylinder material.

Keeping the above factors in view, it is observed that suitable means must be provided to dissipate the excess heat from the cylinder walls, so as to maintain the temperature below certain limits. The engine gives best performance at temperature from 70 to 85 degree Celsius, which is called the optimum temperature limit. In optimum temperature limit, the engine overhaul efficiency is highest.

### Methods of Cooling

Various methods used for cooling of automobiles engine are:

- **Air Cooling:** The basic principle involved in this method is to have the current of air flowing continuously over the heated metal surface from where the heat is to be removed. The heat dissipation depends upon following factors:

1. Surface area of metal in contact with air.
2. Mass flow rate of air.
3. Temperature difference between the heated surface and air.
4. Conductivity of metal used for engine.

Use of copper, aluminum and steel alloys has been made to improve heat transfer because of their better thermal conductivity.

- ❖ **Water Cooling:** In water cooling, the engine cylinders are surrounded by water jackets through which the cooling water flows. Heat flows from the cylinder walls into water which goes to the radiator where it loses its heat to the air.

Water cooling systems are of two types:

- (a) Thermo-siphon System
- (b) Pump Circulation System

In the modern automobiles, pump circulation system is employed because in this system the required size of the radiator is much smaller than the thermosiphon system and the cooling is also faster.

### Other Methods of Cylinder Cooling

Apart from the two widely used methods, i.e. air cooling and water cooling as discussed above, various other methods have been used to increase the cooling efficiency according to the need of the circumstances. The methods are:

- ❖ **Liquid cooling:** Sometimes instead of water, other liquids having higher boiling points are used for engine cooling. The examples are glycerin (boiling point  $290^{\circ}\text{C}$ ) and ethylene glycol (b.p.  $195^{\circ}\text{C}$ ). Higher boiling point increases the capacity of the liquid to carry heat and consequently weight of the coolant and hence that of the radiator is decreased.
- ❖ **Pressure sealed cooling:** The boiling point of water is raised at higher pressures, with consequent reduction in coolant and the radiator weights and greater thermal efficiency of the engine due to higher operating temperatures. For approximately  $10\text{ kN/m}^2$  increase in pressure, the boiling point is raised by  $2.5^{\circ}\text{C}$ . To achieve this special pressure, a sealed radiator cap is used. The pressure blow off valve opens when the pressure in the system exceeds a certain predetermined value, say  $50\text{ kN/m}^2$ . A vacuum valve is provided to safeguard against the radiator collapse due to vacuum if the steam inside suddenly condenses to form a vacuum.

In some engines, instead of an overflow pipe, an expansion reservoir is provided. This is so connected with the radiator that it receives the excess cooling water as the engine temperature and hence the cooling water temperature increases. When the cooling water cools down, its volume decreases and the cooling water in the reservoir returns to the radiator. The reservoir is usually made of translucent plastic so that it can indicate the level of the coolant anytime.

## Advantages of Pressure sealed cooling system

- There is no loss of coolant.
- Cooling efficiency of the system is not decreased at high altitudes, where due to low temperature pressure, the boiling point is otherwise low.

## Components of Cooling System

The cooling system is made up of the passages inside the engine block and heads, a water pump to circulate the coolant, a thermostat to control the temperature of the coolant, a radiator to cool the coolant, a radiator cap to control the pressure in the system, and some plumbing, consisting of interconnecting hoses to transfer the coolant from the engine to radiator.

- The Radiator
- Pressure Cap & Reserve Tank
- Thermostat
- Freeze Plugs
- Head Gaskets & Intake Manifold Gaskets
- Radiator Cooling Fans
- Water Pump
- Bypass System
- Hoses

## How does a cooling system work?

A cooling system works by sending a liquid coolant through passages in the engine block and heads. As the coolant flows through these passages, it picks up heat from the engine. The heated fluid then makes its way through a rubber hose to the radiator in front of the car. As it flows through the thin tubes in the radiator, the hot liquid is cooled by the air stream entering the engine compartment from the grill in front of the car. Once the fluid is cooled, it returns to the engine to absorb more heat. The water pump has the job of keeping the fluid moving through this system of plumbing and hidden passages.

A thermostat is placed between the engine and the radiator to make sure that the coolant stays above a certain preset temperature. If the coolant temperature falls below this temperature, the thermostat blocks the coolant flow to the radiator, forcing the fluid instead through a bypass directly back to the engine. The coolant will continue to circulate like this until it reaches the design temperature, at which point, the thermostat will open a valve and allow the coolant back through the radiator.

## Exercise: Assignment

1. List the components of cooling system:

S.No.	Name of component

2. Prepare a poster showing tools used in automobiles:

3. A. Fill in the blanks:

- a) Quantity of \_\_\_\_\_ given to the cylinder walls is \_\_\_\_\_ and if this heat is not removed from the cylinders it would result in the \_\_\_\_\_ of the charge.
- b) In Air Cooling, current of air flowing \_\_\_\_\_ over the heated metal surface from where the \_\_\_\_\_ is to be removed.
- c) A thermostat is placed \_\_\_\_\_ the engine and the \_\_\_\_\_.
- d) As the coolant \_\_\_\_\_ through these passages, it picks up \_\_\_\_\_ from the engine.

B. Tick the correct answer:

1. Coolant is made of

- a) Oil
- b) Water
- c) Chemical
- d) Liquid

2. Coolant is used for

- a) Heating the engine
- b) Cooling the engine
- c) Firing the engine
- d) Freezing the engine

3. It is not the part of cooling system

- a) The Radiator
- b) Radiator Cooling Fans
- c) Pressure Cap & Reserve Tank
- d) Bonnet
- e) Thermostat

### Checklist for Assessment Activity

Use the following checklist to see if you've met all the requirements for pollution control.

**Part A**

- ❖ Share importance of cooling system in a vehicle.



## Part B

Discuss in class the following:

- What is the meaning of cooling system?
- What are the different components of cooling system used in an automobile?
- Differentiate between air and water cooling.
- Liquid cooling and Pressure sealed cooling.

### Performance standards/criteria covered by this assessment

Performance Standards	Yes	No
Able to explain importance of cooling system		
Able to identify general component of cooling system		

## SESSION - 6: FUEL SUPPLY SYSTEM

### Relevant Knowledge

In the previous level, you studied the names of different components of fuel supply system for SI engine and CI engine. In this level you are going to learn more about the same.

It was already discussed that the basic fuel supply system in an automobile with a petrol engine, consists of a fuel tank, fuel lines, fuel pump, fuel filter, air cleaner, carburetor and inlet manifold. Now, let us discuss about different types of fuel supply system.

### Types of Fuel supply system

- **Gravity System:** In this system, the fuel tank is mounted at the highest position from where the fuel drops into the carburetor float chamber by gravity. The system is very simple and cheap, but the rigidity of placing the fuel tank necessarily over the carburetor is a disadvantage.

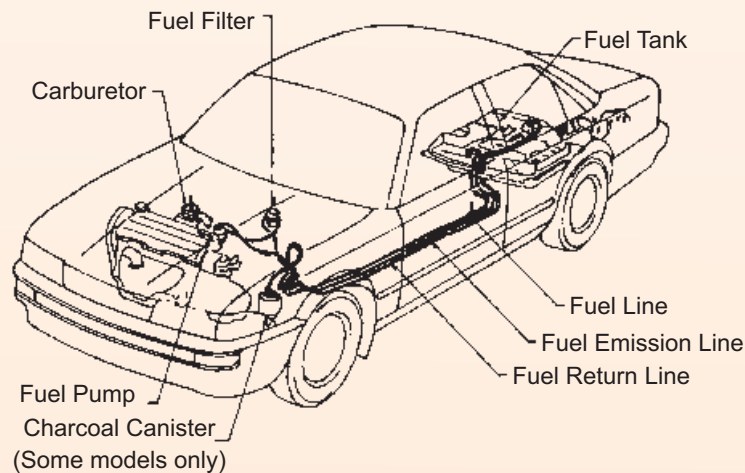


Fig: Fuel Feed System of a Vehicle

- ❖ **Pressure System:** In the pressure system, a hermetically sealed fuel tank is used. Pressure is created in the tank by means of engine exhaust or a separate air pump. For starting, the pump is primed by hand. It is under the pressure thus produced, that, the fuel flows to the float chamber of the carburetor. There are chances of pressure leak, but, the advantage lies in the fact the fuel tank can be placed at any suitable location.
- ❖ **Vacuum System:** This system is based upon the simple fact that the engine suction can be used for sucking fuel from the main tank to the auxiliary fuel tank from where it flows by gravity to the carburetor float chamber.
- ❖ **Pump System:** In this system, a steel pipe carries petrol to the fuel pump which pumps it into the float chamber of the carburetor through a flexible pipe. If the fuel pump is mechanical, it has to be driven from the engine camshaft and hence placed on the engine itself. However, electrically operated fuel pump can be placed anywhere, the rear location (away from the hot engine) reducing the tendency of forming vapour lock.
- ❖ **Fuel Injection System:** The petrol injection system has been used successfully on some modern vehicles (MPFI engines). In this system, the carburetor is dispensed with altogether. The fuel is atomized by means of a nozzle and then delivered into an air stream. Separate fuel injection system is used for each cylinder which controls the mixture under different load and speed conditions.

### Exercise: Assignment

1. List the components of the fuel supply system:

S.No.	Name of component

2. Prepare a poster showing the fuel feed system of a vehicle:

3. A. Fill in the blanks:

- a) Fuel supply system in an \_\_\_\_\_ with petrol engine consists of a fuel tank, fuel lines, fuel pump, fuel filter, air cleaner, carburetor and inlet manifold.

- b) In the Gravity system, the fuel tank is mounted at the \_\_\_\_\_ position.
- c) In the pressure system, a hermitically sealed \_\_\_\_\_ is used.
- d) Petrol injection system has been used \_\_\_\_\_ on MPFI engines.

### Checklist for Assessment Activity

Use the following checklist to see if you've met all the requirements for Fuel Supply System.

#### Part A

- Share importance of the Fuel supply system of a vehicle

#### Part B

Discuss in class the following:

- Different types of fuel supply system used in a vehicle.
- Difference between gravity and pressure system.
- Write the importance of pressure system.

#### Performance standards/criteria covered by this assessment

Performance Standards	Yes	No
Able to explain importance of fuel supply system		
Able to identify fuel supply system of a vehicle		

## SESSION - 7: TRANSMISSION SYSTEM

### Relevant Knowledge

In the previous level, you studied very little about the Transmission System. In this level, you are going to learn more about those systems, i.e. Clutch Assembly, Gear Box Assembly and Propeller Shaft.

#### Clutch Assembly

You have already studied functions of clutch, requirements of clutch and its main components. Now let us learn more about the Clutch Assembly.

#### Types of clutch

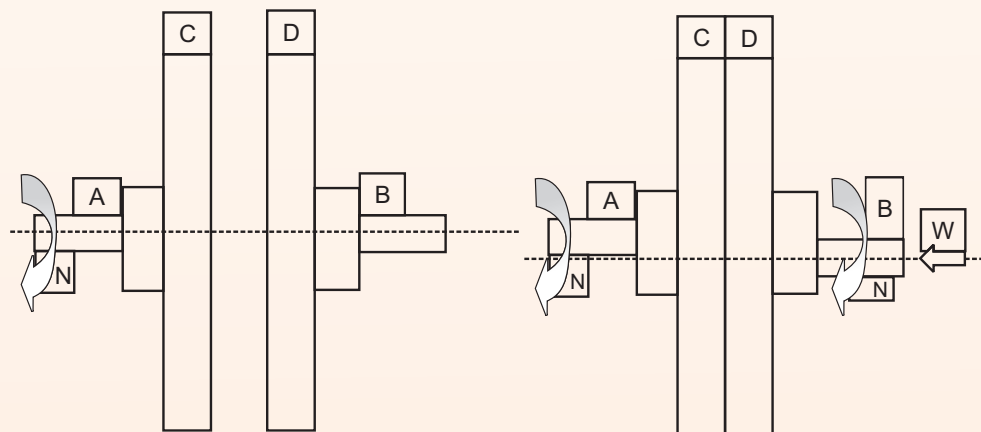
Different types of clutches are as follows:

1. Friction Clutch
  - Single plate clutch
  - Multiplate clutch
    - Wet
    - Dry



- Cone clutch
  - External
  - Internal
- 2. Centrifugal Clutch
- 3. Semi-centrifugal Clutch
- 4. Conical Spring Clutch or Diaphragm Clutch
  - Tapered finger type
  - Crown spring type.
- 5. Positive Clutch – Dog and spline Clutch
- 6. Hydraulic Clutch
- 7. Electro-magnetic Clutch
- 8. Vacuum Clutch
- 9. Over running Clutch or free-wheel unit.

### Principle of Friction Clutches



The Principle of a friction clutch may be explained by means of above figure.

Let shaft A and disc C be revolving at some speed, say  $N$  r.p.m. Shaft B and the disc D keyed to it are stationary, initially when the clutch is not engaged. Now apply some axial force  $W$  to the disc D, so that, it comes in contact with disc C. As soon as the contact is made the force of friction between C and D will come into play and consequently the disc D will also start revolving. The Speed of D depends upon friction force present, which in turn, is proportional to the force  $W$  applied. If  $W$  is increased gradually, the speed of D will be increased correspondingly, till the stage comes when, the speed of D becomes equal to the speed of C. Then, the clutch is said to be fully engaged.

Let  $W$  = Axial load applied  
 $T$  = Torque transmitted

$R$  = Effective mean radius of friction surface.

Then,  $T = \mu WR$

Thus, we see that the torque transmitted by a friction clutch depends upon 3 factors i.e.,  $\mu$ ,  $W$  and  $R$ . This means that increasing any or all of the above factors would increase the amount of torque which a clutch can transmit. However, there are upper limits in each of these cases.

## Gear Box (Transmission) Assembly

The functions of Gear Box have been discussed in the previous level. In this level, you are going to learn more about the transmission.

### Need of a Gear Box

An auto-vehicle has to run on roads of various qualities and types, and at varying speeds. It also encounters with vivid nature of tyre-road adhesion, on level and sloped roads. Having different body profiles, various driving needs such as idling and quick acceleration etc., and widely varying driving habits of drivers, the vehicles have to overcome several resistances also. Moreover, they also meet the variations in tractive effort at various speeds. Various resistances encountered by the auto-vehicle during its operation are

- 1. Rolling resistance** which mainly depends upon
  - ❖ Material of the road surface : cemented, asphalted etc.
  - ❖ Quality of the road surface : smooth or rough, dry or wet etc.
  - ❖ Material and design of tyres tread
  - ❖ Inflation (pressure) in the tyre : over-inflated, under-inflated, or correctly inflated
- 2. Gradient resistance** which mainly depends upon
  - ❖ Slope of the road : level, sleepy, down-a-hill, up-the-hill etc.
  - ❖ Mass of the vehicle : light, medium or heavy
- 3. Air resistance** which mainly depends upon
  - ❖ Speed of the vehicle : slow, medium or fast
  - ❖ Speed and direction of the wind : in-favour, against the vehicle's motion or cross-winds
  - ❖ Body profile of the vehicle : streamlined, bluff body or otherwise
- 4. Resistance due to driving requirements** which mainly depends upon
  - ❖ Need of idling, or constant speed
  - ❖ Acceleration and its rate
  - ❖ Driving habits
  - ❖ Frictional resistance

**Sum of all these resistances is known as Total Resistance.**

## Types of Transmission (Gearbox)

Several kinds of transmissions are employed on auto-vehicles. These can be classified as follows:

### 1. Manual Transmission

The manual transmission i.e., the selective type gearboxes are the conventional means. They are widely used in cars, buses and trucks. It is also known as standard or conventional type Gear box.

- Sliding mesh gear box
- Constant mesh gearbox
- Synchromesh gearbox without overdrive
- Synchromesh gearbox with overdrive

### 2. Semi-automatic transmission

Semi-automatic transmission incorporates an intermediate arrangement which is combination of manual and automatic systems.

- Electric controlled with a fluid drive
- Electric controlled with overdrive
- Fluid-torque drive

### 3. Automatic Transmission

**Automatic transmission** is used mainly on luxury cars, or heavy vehicles which require frequent change of gears in the city and crowded highway driving. In automatic transmission, the different ratios between the engine crankshaft and the wheels are achieved by automatic means. The driver does not need to shift gears, such transmission make use of a fluid coupling or torque converter, as well as mechanical, hydraulic or electrical controls.

- Hydromatic drive
- Torque-converter drive

## Principle of Gearing

A simple Gearing principle is shown below where two gear are engaged with each other. Gear A is called Driving Gear or Driver and Gear B is called Driven Gear.

Suppose,

$N_A$  = Speed of Gear A    $T_A$  = Number of teeth on Gear A

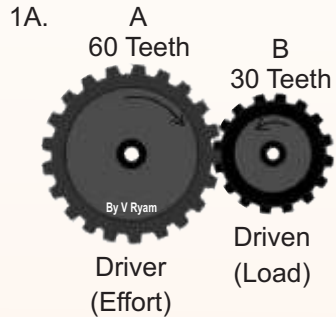
$N_B$  = Speed of Gear B    $T_B$  = Number of teeth on Gear B

Therefore, the speed ratio of Gear A and Gear B is

$$\frac{N_B}{N_A} = \frac{T_A}{T_B}$$

With the following example, the principle of gearing will be very clear to you.

In the example below, the DRIVER has 60 teeth and because it is the largest we say that it revolves once. The DRIVEN gear has 30 teeth. Simply divide 60 teeth by 30 teeth to work out the number of revolutions of the driven gear.



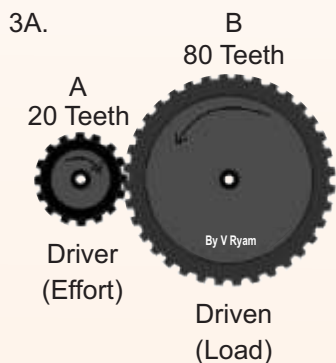
**Work out the Velocity Ratio (Gear Ratio);**

$$\frac{\text{Distance moved by Effort}}{\text{Distance moved by Load}} = \frac{25T \text{ (Gear A)}}{75T \text{ (Gear B)}}$$

$$= \frac{3}{1} = \frac{\text{Input movement}}{\text{Output movement}}$$

$$= \text{Driver : Driven}$$

$$= 3 : 1$$



$$\frac{\text{Distance moved by Effort}}{\text{Distance moved by Load}} = \frac{20T \text{ (Gear A)}}{80T \text{ (Gear B)}}$$

$$= \frac{4}{1} = \frac{\text{Input movement}}{\text{Output movement}}$$

$$= \text{Driver : Driven}$$

$$= 4 : 1$$

## Propeller Shaft and Universal Joint

The rotary motion of the transmission main shaft is carried out through the propeller shaft to the differential casing, the rear wheels to rotate. The propeller shaft has to withstand the torsional stresses of the transmitting torque and yet, it must be light and well balanced so that vibrations and whip will not occur at high speeds. For these reasons, it is made of a strong steel tube. Solid propeller shafts are also used. Some applications include bearings at or near the propeller shaft center to support the shaft. On some applications, the propeller shaft is in two sections, supported by a center bearing and coupled together by universal joint.

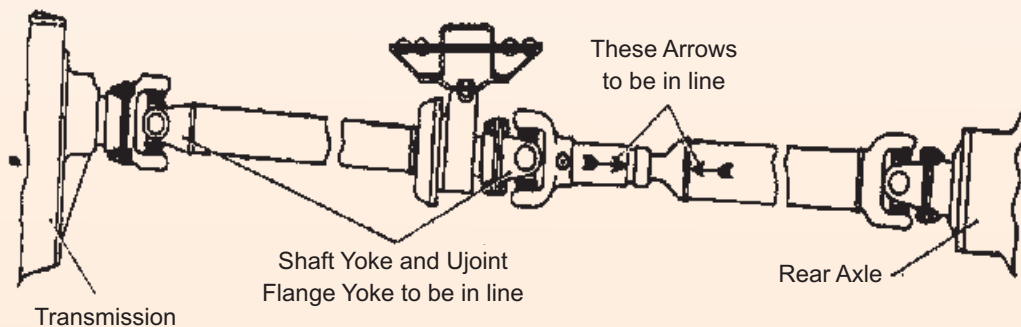


Fig: Arrangement of a Two-Piece Propeller Shaft

It is to be noted that the transmission main shaft and the differential pinion shaft are not in one horizontal level. The rear axle housing with differential is attached to the frame by springs, therefore, the distance between the gear box and the differential, changes due to road irregularities. This also changes the angle of driver. In order that the propeller shaft must take curve of these two changes it is provided with one or more universal joints to permit variations in the angle of drive. Also, it must be provided with a sliding joint that permits the effective length of the propeller shaft to change.

### Requirements of a Propeller Shaft

For efficient discharge of its functions, the following requirements are expected in a propeller shaft.

- High torsional strength (therefore, they are made circular in cross-section, preferably hollow circular).
- Toughened and hardened (they are generally induction hardened).
- Efficiently welded (they are generally welded by submerged arc CO<sub>2</sub> process).
- Dynamically balanced (they are tested on electronic balancing machine).
- Least stress concentration (the fillet radius is ground on centreless grinding machine).
- Reduced thrust loads under high torque.
- Higher fatigue life (to achieve it, they are made of superior quality steel).

**Note:** *The size selection of propeller shaft depends on the following basic parameters*

- Continuous operating torque
- Continuous true running angles
- Desired service life
- Power source

### Universal Joints

An universal joint is used where two shafts are connected at an angle to transmit torque. In the transmission system of a motor vehicle, the transmission main shaft, the propeller shaft and the differential pinion shaft are not in one line, and hence the connections between them are made by universal joint which is used to connect the transmission main shaft and the propeller shaft. The other universal joint which is used to connect the other end of the propeller shaft and the differential pinion shaft. Thus, connections between the three shafts are flexible and at an angle with each other. The universal joint permits the torque transmission not only at an angle, but also while this angle is changing constantly.

A simple universal joint consists of two Y-shaped yokes, one on the driving shaft and other on the driven shaft, and a cross-piece called the spider. The four arms of spider, known as trunnions, are assembled into bearings in the ends of the two shaft yokes. The driving shaft and the driven shaft are at an angle to each other, the bearings in the yokes permits the yokes to swing around on the trunnions with each revolution.



A simple universal joint does not transmit the motion uniformly when the shafts are operating at an angle, except in constant velocity type universal joint. Because, the pivot pins do not revolve in the same plane, the driven shaft will increase to a maximum and decrease to a minimum, twice in each revolution. Although the degree of variation is small, it may be minimized by the use of two universal joints. The two joints are arranged so that the nonuniform rotation of each joint tends to neutralize that of the other.

### Types of Universal Joints

In automobiles, the following types of universal joints are used.

- Cross
- Constant velocity
- Rubber coupling
- Pot type joints
- Lay rub type joints

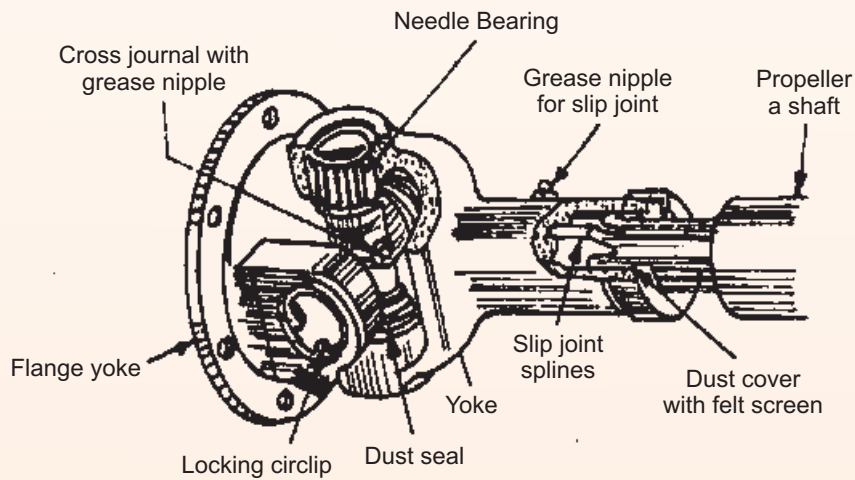


Fig: Universal joint assembly

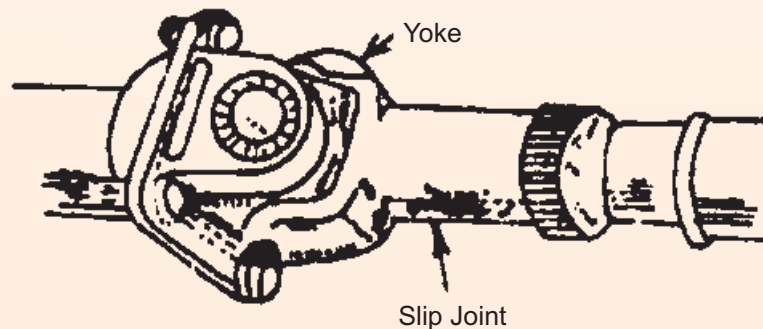


Fig: Universal joint as fitted to Propeller shaft

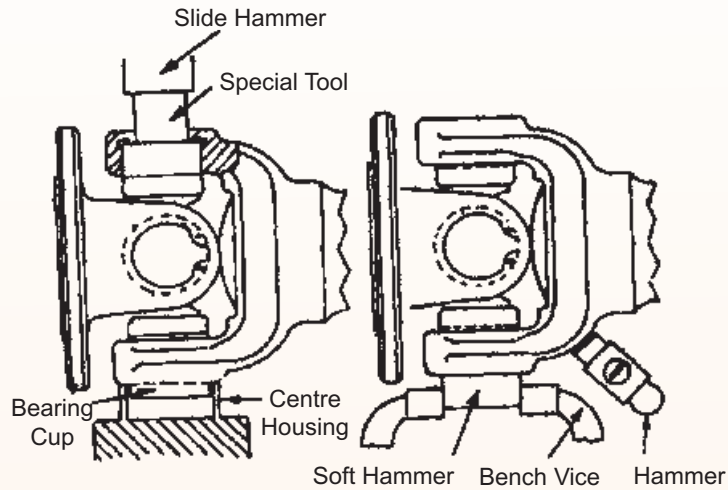


Fig: Removing cups from half shaft yoke

### Exercise: Assignment

1. List the types of clutch:

S.No.	Types of clutch

2. Prepare a poster showing principle of friction clutches:

3. A. Fill in the blanks:

- a) An universal joint is used where two shafts are connected at an angle to \_\_\_\_\_ torque.
- b) A simple universal joint consists of two \_\_\_\_\_ yokes, one on the driving shaft and other on the \_\_\_\_\_ shaft, and a cross-piece called the \_\_\_\_\_.

- c) Automatic transmission is \_\_\_\_\_ mainly on luxury cars, or heavy vehicles which require \_\_\_\_\_ change of gears in the city and crowded highway driving.
- d) The rotary motion of the \_\_\_\_\_ main shaft is carried out through the \_\_\_\_\_ shaft to the differential casing, the rear wheels to rotate.

**B. Tick the correct answer:**

**1. In automobiles, the following types of universal joints are used**

- a) Cross type
- b) Constant velocity type
- c) Non Rubber coupling
- d) Pot type joints
- e) Lay rub type joints

**2. Size selection of propeller shaft depends on**

- a) Continuous operating torque
- b) Continuous true running angles
- c) Desired service life
- d) Non power source

**3. Air resistance depends upon**

- a) Speed of the vehicle
- b) Speed and direction of the wind
- c) Body profile of the vehicle
- d) Fuel used in the vehicle

### Checklist for Assessment Activity

Use the following checklist to see if you've met all the requirements for pollution control.

#### Part A

- Share the importance of a transmission system used in workshop.

#### Part B

Discuss in class the following:

- Various resistances encountered by auto vehicle during its operation.
- Different types of transmissions used in automobiles.
- Differentiate between propeller shaft and universal joint.
- Requirements of propeller shaft.
- Function of front axle.

## Performance standards/criteria covered by this assessment

Performance Standards	Yes	No
Able to explain importance of transmission system		
Able to identify general components of transmission system		

## SESSION - 8: FRONT AXLE

### Related Information

Axle is a central shaft for a rotating wheel or gear. Axles are an integral component of a wheeled vehicle.

### Function of the Front Axle

- ❖ It carries the weight of the front of the vehicle.
- ❖ It carries stub axle king pin steering arm by which the vehicle can be steered.
- ❖ It works as cushion through its spring for a comfortable ride.
- ❖ It controls the ride through shock absorber fitted on it.
- ❖ It carries the brake system with which the moving vehicle can be stopped.
- ❖ In case of a four wheel drive, it also transmits power to road wheels. It carries hubs and wheels.

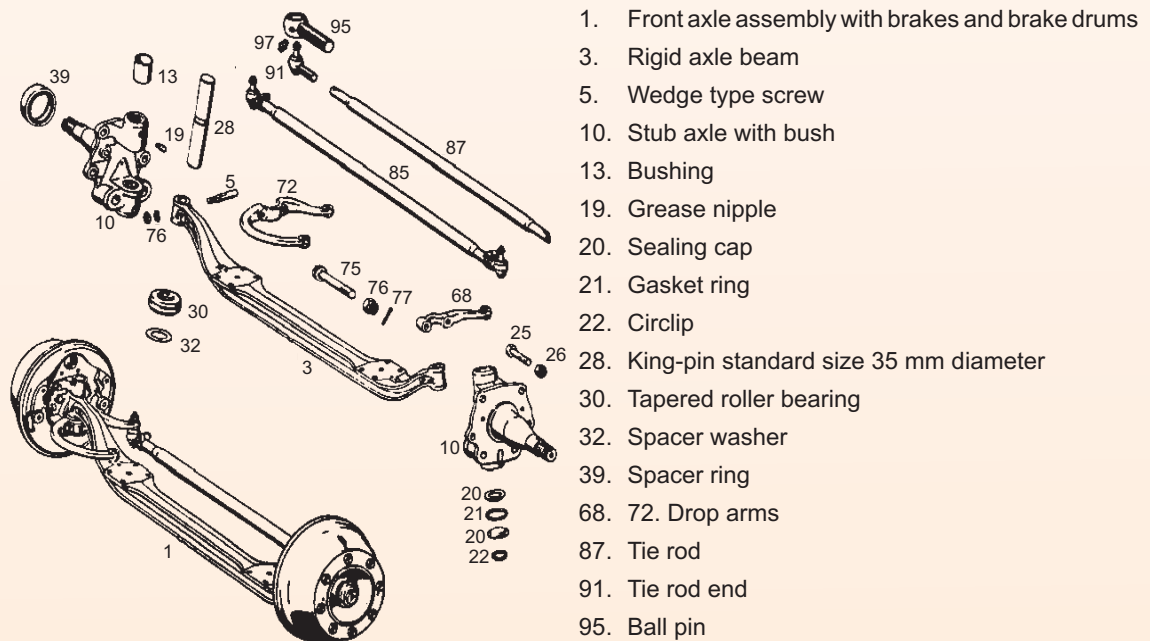


Fig: Exploded view of a heavy duty front axle used on a Tata truck

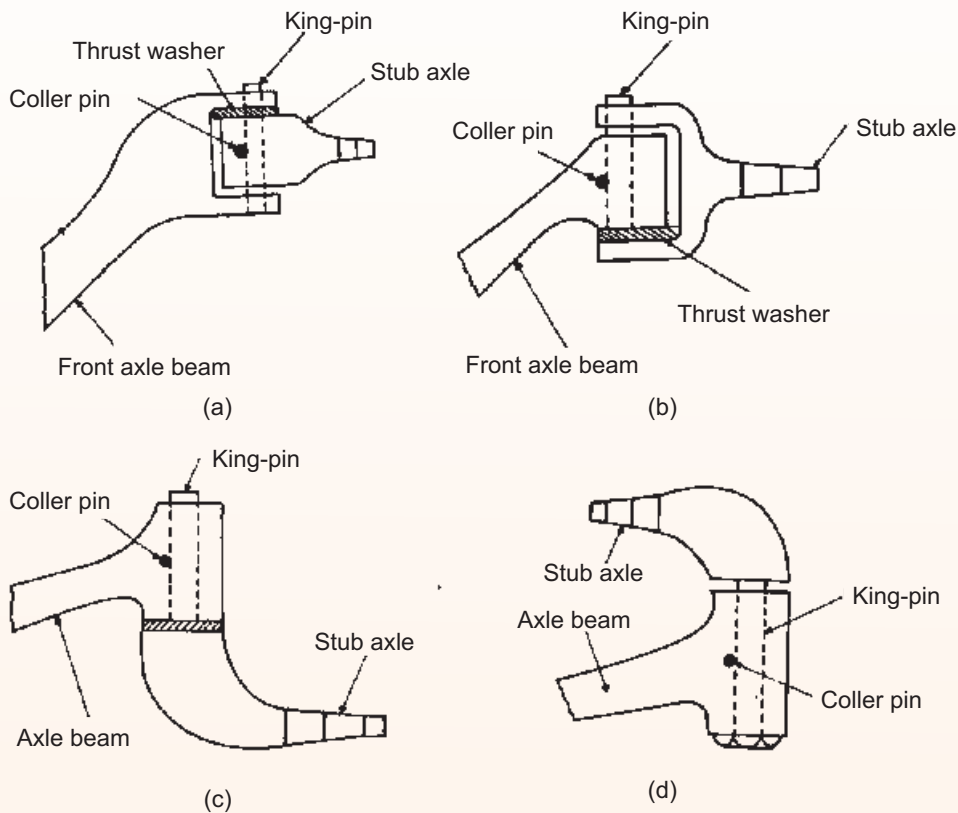


Fig: Different types of stub axles (a) Elliot Type, (b) Reverse Elliot Type, (c) Lamoine Type, and (d) Reverse Lamoine Type

## Types of Front Axle

- Live front axle (used for front wheel drive and 4X4 type of drive).
- Dead front axle (used for 4X2 type of drive).

## Types of arrangement of Front Axle

There are two types of Front Axle arrangements employed on automobiles which, are as follows:

1. **Stub-axle with rigid axle beam type:** This type was used earlier on all types of vehicles, but now it finds use on medium and heavy commercial vehicles only, such as trucks and buses.
2. **Stub-axle without rigid axle beam type:** It is widely used on cars and light commercial vehicles.

## Rigid Axle Beam

The Rigid Axle Beam is a stationary structural member used to sustain bending and torsional loads and to connect the stub axles. The bending is induced in its central region and due to the vehicle's weight the torsional loads are caused near its ends due to the wheel's braking. Since the I-section resists bending and the circular section can resist torsion more efficiently, the axle

beam consists of a central region made of I-section and the ends of circular section. An elliptical section is also used sometimes.

### Stub Axle

A stub axle is an inter-mediatory small shaft between the road wheel and the front (dead) axle. On one end it remains connected to the axle beam by means of a king pin or a ball joint, while the other end, the front wheel is mounted on it. The stub axles are available in different shapes and they are connected to the axle beam in different styles. Depending upon the shapes, and styles of connection, the stub axles can be one of the following types.

1. Elliot types
2. Reversed Elliot type as used on Eicher 10.90, Ashok Leyland Vicking, Tata 407 etc.
3. Lamoine type generally used on front axle of tractors
4. Reversed lamoine type

### Exercise: Assignment

1. List the functions of the front axle:

S.No.	Name of component

2. Prepare a poster showing parts of axle used in automobiles:

3. A. Fill in the blanks:

- a) Axle is used for \_\_\_\_\_.
- b) A stub axle is an inter-mediatory \_\_\_\_\_ between the road wheel and the front (dead) axle.

- c) Rigid axle beam is a stationary \_\_\_\_\_ member.
- d) In a four wheel drive, the front axle transmits \_\_\_\_\_ to road wheels.

**B. Tick the correct answer**

**1. Front axle is made of**

- a) Iron
- b) Wood
- c) Steel
- d) Aluminum

**2. A stub axle is used for**

- a) Tightening the bolt
- b) Opening the nut
- c) Rotating wheel
- d) Folding the nut

**Checklist for Assessment Activity**

Use the following checklist to see if you've met all the requirements for front axle.

**Part A**

- Share importance of front axle of a vehicle.

**Part B**

Discuss in class the following:

- What is meaning of front axle?
- What are the different types of axles used in automobile?
- Differentiate between Stub-axle with rigid axle beam type and Stubaxle without rigid axle beam type?

**Performance standards/criteria covered by this assessment**

Performance Standards	Yes	No
Able to explain importance of front axle		
Able to identify front axle		

**SESSION - 9: STEERING SYSTEM**

**Related Information**

In the previous level you studied the functions of the steering system and its layout. In this level, you will learn more about the steering system.

**Requirements of Steering System**

For smooth performance of the system, the steering system of any vehicle should fulfill the following requirements:

- It should multiply the turning effort applied on the steering wheel by the driver.



- ❖ It should be to a certain degree irreversible so that the shocks of the road surface encountered by the wheels are not transmitted to the driver's hands.
- ❖ The mechanism should have self-rightening effect so that when the driver releases the steering wheel after negotiating the turn, the wheel should try to achieve straight ahead position.

The readers may bear in mind that the requirements of any system may vary, but, they should have some kind of average compromise.

### Types of Steering System

On the basis of mode of effort application the steering system is divided into two categories:

- ❖ Mechanical Linkage Type Steering System
- ❖ Power Steering System: In this type hydraulic fluid with some mechanism is used for the operation.

### Steering Gears

To accomplish the turning of road wheels by few degrees, it rotates the steering wheel many times. All these are possible only by use of a steering gear. A steering gear serves two main functions.

- ❖ It transforms rotary motion of the steering wheel into the reciprocating motion of the drag link.
- ❖ It assists in multiplying a small effort applied at the steering wheel into a much greater force on the drag link.

### Types of Steering Gear

To perform the above two jobs, several types of steering gear systems are employed on automobiles. Important and commonly used systems among them are the following :

- ❖ Worm and worm-wheel type steering gear.
- ❖ Worm and worm-sector type steering gear as in earlier Austin small cars.
- ❖ Worm and nut type steering gear as in Swaraj Mazda.
- ❖ Worm and roller type steering gear as in Premier Padmini SI and Diesel cars, DJ series jeeps
- ❖ Re-circulating steel balls type steering gear as in Tata 1210, Dodge/Fargo 89 M4, Omni, Eicher 10.70, Tata 407, Tempo Excel-4 pick up truck.
- ❖ Worm and peg (or cam) type steering gear as in Ford FS 16C truck, Morgan Plus 8.
- ❖ Rack and pinion type steering gear as in Maruti 800 Ambassador Diesel, Standard Herald Mark III, Chrysler Alpine cars (UK), A.C. sports cars (UK), Cielo, Fiat Uno, Zen, Terios.

In most of the above types a worm is the basic component which is used in conjunction with wheel, wheel sector, or nut etc.



## Exercise: Assignment

1. List the functions of steering:

S.No.	Functions of Steering

2. Prepare a poster showing parts of steering used in automobiles:

3. Fill in the blanks:

- Steering is used for \_\_\_\_\_.
- A steering gear serves \_\_\_\_\_ main functions.
- Steering gear transforms \_\_\_\_\_ of the steering wheel into the \_\_\_\_\_ of the drag link.
- Several types of steering \_\_\_\_\_ systems are employed on automobiles.

## Checklist for Assessment Activity

Use the following checklist to see if you've met all the requirements for pollution control.

### Part A

- ❖ Share the importance of steering system of a vehicle.

### Part B

Discuss in class the following:

- ❖ What is use of steering?
- ❖ What are the different types of steering gear used in automobiles?

### Performance standards/criteria covered by this assessment

Performance Standards	Yes	No
Able to explain importance of steering		
Able to identify steering system		

## SESSION - 10: REAR AXLE

### Related Information

#### Final Drive

The functions of the final drive are to provide a permanent speed reduction and also to turn the drive round through 90°. The reduction provided is about 4:1 in cars and 10:1 in heavier vehicles. This is done either in one or two stages. For lesser reduction, say unto about 7:1, single reduction is used, while higher reductions are achieved in two steps. The double reduction has to be resorted to, because, otherwise the size of the larger gear becomes too much.

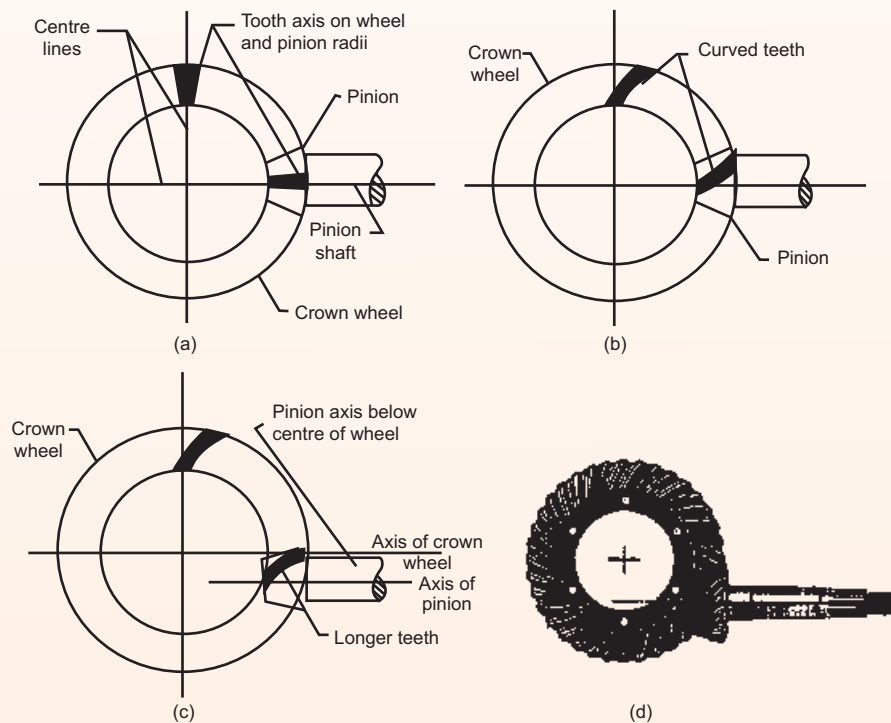


Fig: Crown wheel and bevel pinion geometries of (a) straight teeth or plain bevel type, (b) spiral teed bevel type, (c) hypoid seeth bevel type, and (d) off-centre hypoid-bevel type.

The final drive, in practice, consists of a bevel pinion and a crown wheel. The bevel pinion mounted on a shaft which is connected to the propeller shaft generally through a universal joint. From the crown wheel the drive goes to the differential. Three types of gears are used for the final drive gearing:

- ❖ **Straight Bevel Gears:** These contain the straight teeth. They are therefore simplest and thus the cheapest of all types.
- ❖ **Spiral Bevel Gears:** The spiral bevel gears have curved teeth which result in greater contact of the teeth. Because of this the spiral bevel gears are silent running and stronger than the straight bevel gears.

- **Hypoid Gears:** These types of gears are widely used for final drive these days. As it is clear from the case of hypoid gears, the pinion shaft is placed below the axis of the crown wheel. This permits a lower position of the propeller shaft, thus allowing a low chassis height. The obvious disadvantage is less ground clearance. Further, these are comparatively expensive, difficult to assemble and need special high pressure lubricant because of greater sliding action present in this case.

### Exercise: Assignment

1. List the functions of rear axle:

S.No.	List of Functions

2. Prepare a poster showing tools used in automobiles:

3. Fill in the blanks:

- a) Real axle is used for \_\_\_\_\_.
- b) From the crown wheel the drive \_\_\_\_\_ to the differential.
- c) Hypoid Gears are widely \_\_\_\_\_ for final drive these days.
- d) The functions of the final drive are to \_\_\_\_\_ a permanent speed \_\_\_\_\_ and also to turn the drive \_\_\_\_\_ through 90°.

### Checklist for Assessment Activity

Use the following checklist to see if you've met all the requirements for pollution control.

#### Part A

- Share the importance of the steering wheel.

#### Part B

Discuss in class the following:

- ❖ What is meaning of steering?
- ❖ Types of gear used in steering.
- ❖ Straight Bevel Gears and Spiral Bevel Gears.

#### Performance standards/criteria covered by this assessment

Performance Standards	Yes	No
Able to explain importance of steering in a vehicle		
Able to identify general steering of a vehicle		

## SESSION - 11: SUSPENSION SYSTEM

### Relevant Knowledge

In the first level you learnt about objects and functions of suspension system and various components and types of suspension system. In this level you will learn more about the same.

### Suspension System

After the engine of a vehicle it is the suspension system that holds prime importance because it is the harbinger of a comfortable ride. The suspension system minimizes the impact of a particular road condition providing a safe drive to the occupants of the vehicle. This might sound pretty simple but when you come to think of it seriously it is not as simple. When acceleration comes into force and force translates into raw energy, this energy travels through the frame of the vehicle .without coils and springs, To absorb this, the vertical energy would cause the vehicle to jump up off the road, reducing tyre friction and control, which would result in a heavy bounce back downwards by the car with even greater force, which could be very dangerous. Coil spring and leaf springs absorb all forces and keep the tyres firmly planted to the ground so that the tyre always remains in contact with the ground.

The term suspension is given to the springs, shock absorbers and linkages that connect a vehicle to its wheels. The suspension system mainly serves the purpose of providing safety to the car by minimizing jerks and provides comfort to the occupants of the vehicle.

### Principle of the Suspension System

- ❖ To restrict road vibrations from being transmitted to the various components of the vehicle
- ❖ To protect the passengers from road shocks.
- ❖ To maintain the stability of the vehicle in pitching and rolling.

### Components of the Suspension System

- ❖ **Control Arm:** A movable lever, that fastens the steering knuckle to the frame of the vehicle.
- ❖ **Control Arm Busing:** This is a sleeve which allows the control arm to move up and down on the frame.

- ❖ **Strut Rod:** Prevents the control arm from swinging forward and backwards.
- Ball Joints:** A joint that allows the control arm and steering knuckle to move up and down and sideways as well.
- ❖ **Shock absorbers or Struts:** Prevents the suspension from bounce after spring compression and extension.
- ❖ **Stabilizer Bar:** Limits body roll of the vehicle during cornering.
- ❖ **Spring:** Supports the weight of the vehicle.

### Common problems of the suspension system

- ❖ **Shocks and Struts:** Shocks and Struts are located behind the wheels of a vehicle. They are subject to wear and tear just like other vehicle parts. The signs of a shock wear out are, the car bouncing excessively, leanings hard in corners and jerking at brakes. The sign indicates that the shocks and struts are definitely calling for a change.
- ❖ **Ball joints:** The wearing out of ball joints can get dangerous because if they separate they cause you to lose control over the vehicle which could also be a life risk.

### Preventive Measures

The shocks and struts should be checked frequently for leakages. Ball joints should be checked immediately, incase the motion of the car is not right. Make sure to lubricate the ball joints of your car frequently.

### Terminologies Related with Suspension System

For a better understanding of this chapter, some terms related to suspension system are explained below:

- ❖ **Pitching, Rolling and Bouncing:** When a moving vehicle comes across a road pit or a bump, it experiences a jolt. Consequently, the vehicle stars vibrating and exhibits tendencies of undesired motions. When the tendency of motion is along the length, it is called pitching. If these tendencies are widthwise and along the height of the vehicle, they are termed as rolling and bouncing respectively.
- ❖ **Spring Camber:** The initial curvature provided in a leaf spring is called camber of the spring. The leaf of the spring possesses some radius of curvature due to the camber. The provision of camber is essentially required in them, so that the curved springs may change to a flattened shape on loading.
- ❖ **Yawing:** A phenomenon in which the highly cambered leaf springs exhibit movement about the vertical axis is known as yawing. Tendency of yawing is less in flat springs than in cambered springs.
- ❖ **Dipping:** Tendency of a vehicle to dive in its front on application of brake is called dipping. This is due to the effect of weight transfer during which extra weight is added on the front wheels. Consequently the front wheel suspension is overloaded. This is not a desired condition.



- ❖ **Bottoming:** When a vehicle is overloaded, it causes greater deflection in the springs than their normal specified values. The result is lowering down of the whole vehicle. This is called bottoming. It causes overburdening of the springs and a reduction in the ground clearance.
- ❖ **Sprung Weight:** The weight of the vehicle frame, body, engine, transmission and any other load on these components are supported over the suspension system, therefore, such weights are called as sprung weight. A vehicle should have greater sprung weight for a better suspension. Generally its share is about 65-80% of the whole vehicle weight.
- ❖ **Un-sprung Weight:** Some parts of an auto-vehicle, which are fitted between suspension system and the road surface, are not supported by the suspension system. Weights of these parts are known as un-sprung weight. Examples of such weights are the rear axle assembly, wheels, tyres, brakes and the steering knuckle etc. The fraction of un-sprung weight should be a minimum possible for comfortable ride.
- ❖ **Soft Suspension:** A suspension is said be 'soft' when the road wheels bounce too much even for smaller road shocks. A soft suspension is desired on vehicles, since, it provides greater comfort to the passengers. However, too soft a suspension is not desirable as it results in poorer contact between the wheels and the road. It also results in reduced driving and braking efforts.
- ❖ **Hard Suspension:** It is just opposite to the soft suspension in the sense that, the road wheels do not experience sufficient bounce even for larger road shocks. It, therefore, results in reduced comfort to the occupants of the vehicle. Although, the driving and braking efforts are satisfactory in this case, even though it is not desirable. A good suspension system should be such that it is neither too soft nor too hard.
- ❖ **Spring Stiffness:** The spring is specified by a parameter called 'spring stiffness' (rate of constant). The spring stiffness  $S$  is defined as the load  $P$  required to deflect it by unit length. It is expressed in N/mm or kgf/cm. Thus

$$s = \frac{P}{\delta}$$

Where  $d$  is deflection of the spring, which can be either compression or an extension depending upon the type of spring and its behaviour. A spring of about 15N/mm stiffness is most suitable for soft springing. Different types of automotive springs have the values for their stiffness.

### Exercise: Assignment

1. List the components of suspension system:

S.No.	Name of Components

2. Prepare a poster showing suspension system used in automobiles:

3. Fill in the blanks:

- a) The suspension system \_\_\_\_\_ of a particular road condition providing a \_\_\_\_\_ drive to the occupants of the vehicle.
- b) Tendency of a vehicle to dive in its front on application of brake is called \_\_\_\_\_.
- c) Tendency of a vehicle to dive in its \_\_\_\_\_ on application of brake is called dipping.
- d) The term suspension is given to the \_\_\_\_\_, shock absorbers and \_\_\_\_\_ that connect a vehicle to its wheels.
- e) Shocks and Struts are located \_\_\_\_\_ the wheels of a vehicle.

### Checklist for Assessment Activity

Use the following checklist to see if you've met all the requirements for understanding the Suspension system.

#### Part A

- Share the importance of suspension system in a vehicle.

#### Part B

Discuss in class the following:

- What is meaning of suspension system?
- What are the different components of suspension system?
- List the components of suspension system.
- Differentiate between sprung weight and non-sprung weight.

#### Performance standards/criteria covered by this assessment

Performance Standards	Yes	No
Able to explain importance of suspension system		
Able to identify component of suspension system		



## SESSION 12: WHEELS AND TYRES

### Relevant Knowledge

#### Wheels

The wheel is an important component of a vehicle. Wheel is assembly of hub, disc or spokes, rim, tyre and tube. The wheels not only support the weight of the vehicle, but also protect it from road shocks.

#### Tyre

The tyre is mounted on the wheel rim. It has to carry the vehicle load and provide a cushioning effect.



Fig: Tyre

#### Types of Tyres

Tyres may be of the following types:

1. **Tube tyre:** Tube tyre is the traditional tyre. It encloses a tube in which air is forced to a high pressure as a cushioning medium. The outer position of the tyre which rolls on the road is made of synthetic rubber and is called tread. On the inner edges, beads are formed by reinforcing with steel wires. The beads act as strong shoulders, for bearing against the wheel rim. Rayon cords are formed into a number of piles. Where the beads and cords give strength to the tyre, the threads provide resistance against slipping and thicker surface at the outer periphery.
2. **Tubeless Tyre:** Tubeless tyre does not enclose the tube. The air under pressure is filled in the tyre itself. The inner construction of this tyre is almost the same as that of the tube tyre. A non-return valve is fitted to the rim through which the air is forced inside the tyre.

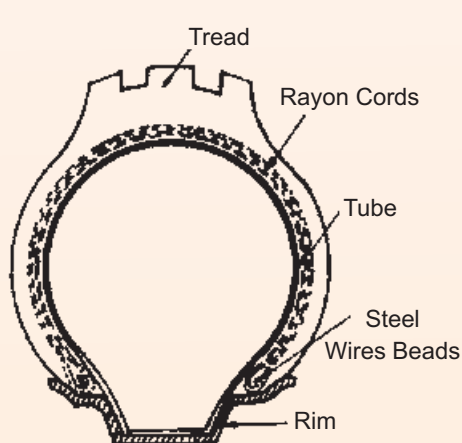


Fig: Traditional Tube Tyre

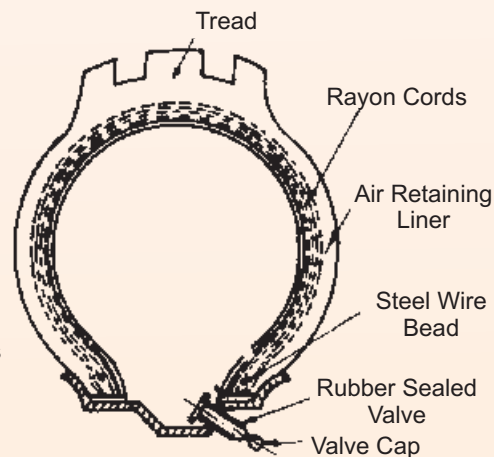


Fig: Tubeless Tyre

#### Advantages of Tubeless Tyre

- The tubeless tyres are lighter and run cooler than tube tyre.



- The main advantage of a tubeless tyre is that it retains air for a long period even after being punctured by nail, provided the nail remains in the tyre. But, the tube tyre releases the air almost immediately after being punctured.
- Any hole in the tubeless tyre can be repaired simply by rubber plugging.
- Ordinary punctures can be repaired with removing the tyre from the wheel.
- It can be retreated in the same manner as the tube tyre.

The tubeless and tube tyres are called pneumatic tyres, in which the air is forced inside the tube itself or in a tube which is fitted in the tyre. In both the cases, air is the cushioning medium. But in solid tube, it is not so. Neither the air is forced inside the tyre nor the tube is enclosed inside it. The tyre is completely solid and is mounted on the wheel rim. It runs for a life long time. Because, it is a heavy tyre and there is no chance of being punctured. Once it is heavy and does not provide cushioning effect, it is not used on automobiles. Its use is limited to children's tricycles.

### Exercise: Assignment

1. List the type of tyres:

S.No.	Name of Tyres

2. Prepare a poster showing wheel and tyre used in automobiles:

3. Fill in the blanks:

- a) Tube tyre is \_\_\_\_\_ tyre.
- b) The tyre is \_\_\_\_\_ on the wheel rim.
- c) The tubeless and tube tyres are called \_\_\_\_\_ tyres.
- d) Pliers is used to \_\_\_\_\_ small objects and either \_\_\_\_\_ or loosen parts.



## Checklist for Assessment Activity

Use the following checklist to see if you've met all the requirements for understanding about Wheels and Tyres.

### Part A

- ❖ Share importance of wheels and tyres used in a vehicle.

### Part B

Discuss in class the following:

- ❖ What is meaning of wheels and tyres?
- ❖ What are the different types of tyres used in vehicles?
- ❖ Differentiate between tyres and tubes?
- ❖ Advantage of tubeless tyres.

### Performance standards/criteria covered by this assessment

Performance Standards	Yes	No
Able to explain importance of tyres and wheel		
Able to identify different type of tyres.		

## SESSION - 13: BRAKES

### Relevant Knowledge

#### Principle of Braking

The brake is a friction creating device which causes speed reduction of the vehicle at a faster rate than the speed reduction obtained by changing the gears and closing-down the accelerator. However, this rate cannot be high enough to stop the vehicle instantaneously. It is because a vehicle of weight  $W$  moving at a speed  $V$  possesses kinetic energy whose value is given by

$$\text{K.E.} = \frac{1}{2} \frac{W}{g} V^2$$

In order to bring the vehicle to rest ( $\text{K.E.} = 0$ ), some work has to be done on the wheels. The work (or braking work) is the product of average frictional resistance  $F_R$  at the road/wheel junction and the distance  $d$  moved by the vehicle before halting. Thus from work-energy relation of vehicle's dynamics.

**Braking work done = K.E.**

$$F_R \cdot d = \frac{1}{2} \frac{W}{g} V^2$$

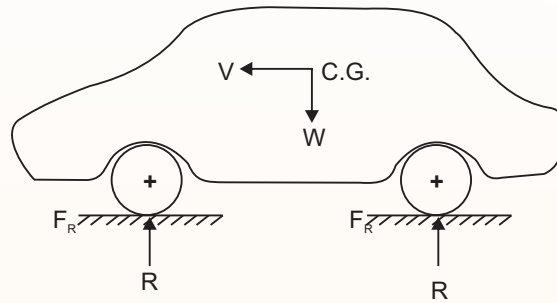


Fig: The work done on the brakes should be equal to the kinetic energy of moving vehicle, to stop it.

Here,  $d$  is known as stopping distance or braking distance.

### Requirements of a good breaking system:

- The brakes should stop the vehicle in shortest possible distance and time.
- The brakes should work equally well on fair or bad roads.
- Pedal effort applied by the driver should not be more so as not to strain the driver.
- Brakes should work equally well in all weathers.
- It should have very few wearing parts.
- It should require little maintenance.
- Brakes, when applied should not disturb steering geometry.
- There should be minimum sound when brakes are applied.

### Exercise: Assignment

1. List the different types of brakes used in automobiles:

S.No.	Types

2. Draw the photograph of brake of a vehicle:

### 3. Fill in the blanks:

- a) Brakes are used for \_\_\_\_\_ component of a vehicle.
- b) Brakes are used for \_\_\_\_\_.
- c) Functions of a brake is \_\_\_\_\_ or \_\_\_\_\_ vehicle .
- d) Brake should work in \_\_\_\_\_ or \_\_\_\_\_ roads.

### Checklist for Assessment Activity

Use the following checklist to see if you've met all the requirements for Assessment Activity.

#### Part A

- ❖ Role of brake

#### Part B

Discuss in class the following:

- ❖ Importance of brakes in an automobile
- ❖ Principle of brakes for the automobiles
- ❖ Properties of good brakes.

#### Performance standards/criteria covered by this assessment

Performance Standards	Yes	No
Able to draw the brake		
Able to identify the components of wheel and rim.		

## SESSION - 14: ELECTRICAL AND ELECTRONICS SYSTEM

### Relevant Knowledge

In the previous level you studied the name of various electrical and electronic systems and their components. In this level you will learn the functions of those components and the details about the lead acid battery, which is generally used for almost all types of vehicles. Before starting the above topics let us learn about some fundamentals of electrical and electronic system, which shall be more useful to you.

#### Fundamentals

##### ❖ Amperage (Amps or A)

The Amp is the unit of electron flow, or how many electrons are passing along a conductor in a second.

Amps (A) = I or 'Intensity' of the current flow.

##### ❖ Voltage (Volts or V)

It is the measurement of electric potential or the attracting / repelling force causing electrons to flow through the circuit.

Volts (V) = E or 'EMF' (Electromotive Force).

#### • Resistance (Ohms or O)

An ohm is the unit of resistance or how hard a conductor resists the flow of electrical current.

Ohms (O) = R or 'Resistance' to electron flow.

#### • Ohm's Law

The flow of current in a circuit is directly proportional to the applied voltage and inversely proportional to the resistance. Ohm's Law is expressed as an equation that shows the relationship between voltage (E for EMF), current flow (I) and resistance (R).

$$E = I \times R \text{ or Voltage} = \text{Amps} \times \text{Resistance}$$

#### • Power

Many electrical devices are rated by how much power they consume, rather than by how much they produce. Power consumption is expressed in watts. It is denoted by the letter W.

The relationships among power, voltage, and current are expressed by the Power Formula:

$$W = E \times I$$

$$W = V \times I$$

As per Ohm's Law  $V = I \times R$

$$\text{Therefore, } W = \frac{I^2}{R}$$

$$\text{Or } W = I^2 \times R$$

### Functions of major components of Auto electrical system

#### • Battery

An automotive battery is an electrochemical device capable of producing electrical energy. It has several important functions which are as follows:

- It operates the starting motor, ignition system, electronic fuel injection, and other electrical devices for the engine during cranking and starting.
- It supplies all the electrical power for the vehicle accessories whenever the engine is not running or when the vehicle's charging system is not working.
- It acts as a stabilizer of voltage for the entire automotive electrical system.
- It stores energy for extended period of time.

#### • Starting Motor (Cranking Motor)

The function of starting motor is to start the engine by drawing direct current (dc) from the

battery. While cranking the engine with the help of the starting motor, it draws around 250 Amps of current from the battery for few seconds (4-5 sec.).

#### ❖ **Alternator**

The functions of alternator are as follows:

- It produces alternating current when the engine is running (the alternator is run by a V-belt connected with engine crank shaft pulley).
- It also converts the alternating current into direct current with the help of rectifier fitted along with it.
- It is the source of electricity in automobile when the engine is running.
- When the engine is running the alternator charges the battery by supplying the current to the battery through the charging circuit.

#### ❖ **Cut Out Unit**

This is fitted into the charging circuit. It is a safety device for the battery in automobile. When the alternator / dynamo voltage is more than the battery voltage it helps to flow the current from alternator / dynamo to battery. But when the alternator / dynamo voltage is less than the battery voltage it avoids to flow the current from battery to the alternator / dynamo by cutting out the contact breaker points.

#### ❖ **Voltage and Current Regulator**

The function of voltage regulator is to regulate the voltage (12 volts to 14.2 volts) in the circuit.

The function of current regulator is to regulate the current flow in the circuit as per the demand of various electrical and electronic components.

#### ❖ **Ignition Coil**

It is fitted in the ignition system of engine. It is just like a step up transformer. The function of ignition coil is to convert 12 volt dc to around 22000 volts dc (low tension current in to high tension current) and supply to the spark plugs.

#### ❖ **Distributor**

The function of distributor is to distribute the high tension current to the spark plug according to the firing order.

#### ❖ **Spark Plug**

The function of spark plug is to create the spark in the combustion chamber according to the firing order to ignite the air and fuel mixture.

#### ❖ **Lighting System**

Head Light helps the driver to drive the vehicle at night. The functions of head lights are

- 1) It increases visibility at night
- 2) It helps to over take the other vehicle

3) By using dipper switch it helps the opposite drivers to drive safely.

**Side Lights** are used for parking purpose.

**Rear Light** is for giving indication to the road users behind it.

**Break Light:** It operates when the driver applies the break which indicates the other road users behind it.

**Reverse Light:** This light glows when drivers engage the reverse gear of the vehicle, which, warns other road users behind the vehicle.

**Fog Lamps:** The colour of fog lemp is amber (yellow). The amber colour light rays have the quality to penetrate into fog. So, during foggy climate this light helps the driver and other road users use the road safely.

**Left and Right Indicator lamps** help to take turn to left or right.

**Interior Lights:** There are two types of interior lights.

- 1) Dash board panel lights which helps the driver to read all the meters such as Speedo meter, oil pressure gauge, etc.
- 2) Cabin lights helps the occupants' of the vehicle.

### Other Important Accessories

- ❖ **Horns:** The function of horn is to warn other road users to clear the road for the safe movement of the vehicle.
- ❖ **Wind Screen wiper:** The function of wind screen wiper is to clean the wind screen while raining to have a clear view in front of the vehicle.
- ❖ **Electric fuel pump:** The function of fuel pump is to supply the fuel to the curburettor or injectors from the fuel tank.
- ❖ **Fuel gauge:** The function of fuel gauge is to indicate level of fuel or quantity of fuel in the fuel tank.
- ❖ **Sensors and actuators:** In the modern vehicles sensors and actuators are fitted in various system of engine along with computer control system. The function of all those sensors and actuators shall be discussed in the next level.
- ❖ **Battery and its Importance:** The battery is the main power source for the entire vehicle. It supplies electrical energy when starting the vehicle and when accessories are operating with the engine off or at low idle. The battery will also compensate for any shortage of power from the alternator when the electrical load is especially heavy. For this reason the battery should always be checked first whenever a vehicle is brought in with an electrical problem.

The storage battery is an electrochemical device that converts electrical energy into chemical energy and stores this energy until electrical energy is once again needed.

Electrical energy is produced by a chemical reaction between two dissimilar conductors (plates) that are immersed in an electrolyte. The amount of electrical energy a battery can produce depends upon the size, weight and active area of the materials in the plates and the quantity of sulfuric acid in the electrolyte. When all the active materials on the plates have reacted with the electrolyte, the battery is said to be in a discharged state.

### Design of Conventional Battery

A lead-acid storage battery consists of seven basic components:

- ❖ Positive Plates
- ❖ Negative Plates
- ❖ Separators
- ❖ Electrolyte
- ❖ Container (or case) and cover
- ❖ Inter cell connectors
- ❖ Terminals

### Positive and Negative Plates

The “framework” of the battery plates is the grid, which is made primarily of lead for low electrical resistance and high conductivity. The grid conducts current to and from the active materials on the positive and negative plates. In a conventional battery, the grid is made from an alloy of lead and antimony.

When the grid is “pasted” with active materials it becomes either a negative or positive plate. The active material that forms a positive plate is a **lead oxide paste** which is applied evenly to the **grid**.

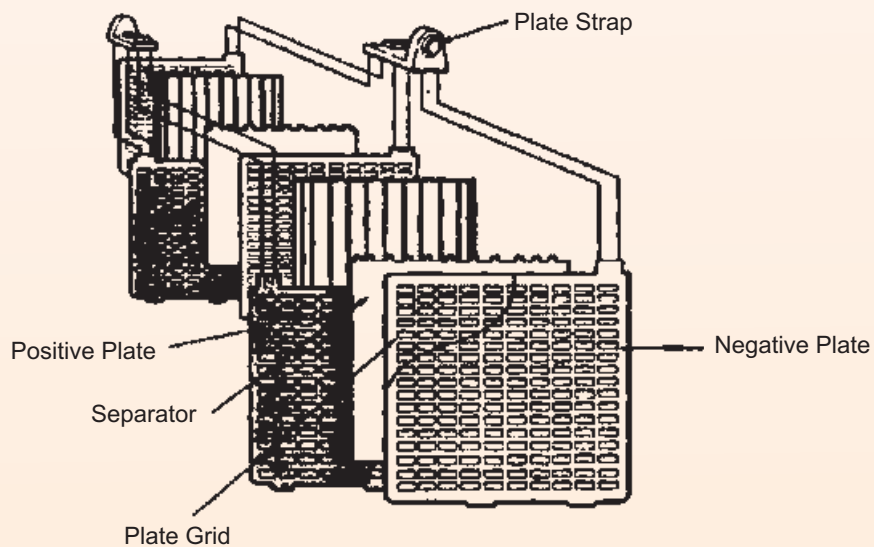


Fig: Elements Constructions



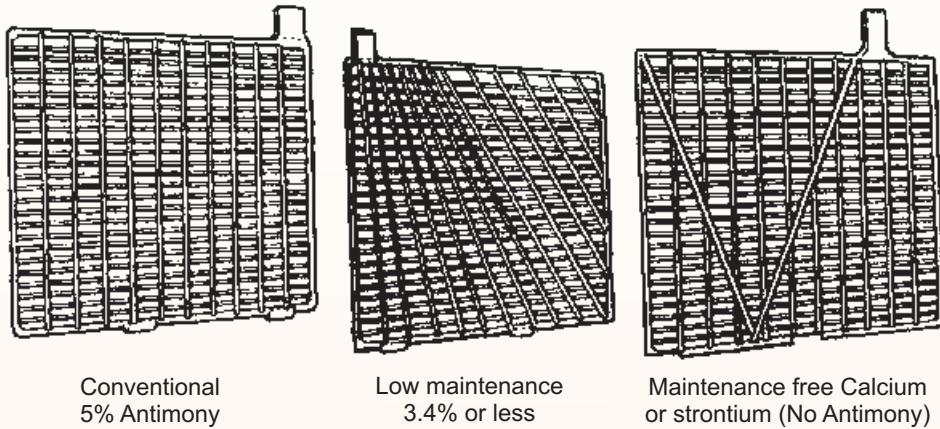


Fig: Battery Plate Grids

The plate is then given a “forming” charge which electrochemically converts the paste material into lead peroxide. The lead peroxide is composed of very small grains or particles which provide a high degree of porosity. This allows the electrolyte to penetrate the plate. A negative plate is formed when the grid is pasted and formed into sponge lead.

### Separators

If positive and negative plates, is allowed to touch each other, they will quickly short out and lose their potential energy. To prevent this contact, thin sheets of non-conducting, micro porous material called separators are placed between each pair of plate.

The assembly resulting from combining one positive plate group and one negative plate group together, with separators, is known as an element. A plate strap connects the lugs at the top of all the positive plates. A second plate strap connects the negative plates.

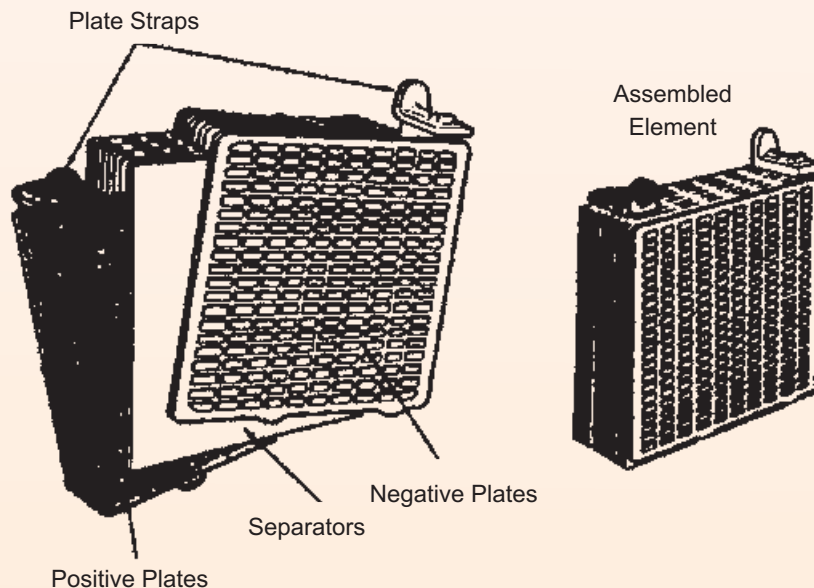
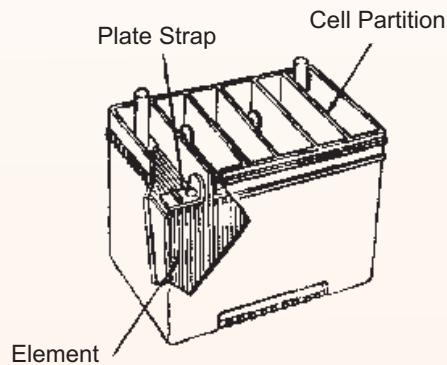


Fig: Element Construction

## Battery Case

The battery case contains the plate and separator assemblies, or cell elements, and the electrolyte. The case is made of polypropylene, hard rubber or other plastic-like material. It is designed to:

- ❖ Withstand temperature extremes of hot and cold.
- ❖ Resist vibration caused by mechanical shock.
- ❖ Resist acid absorption.

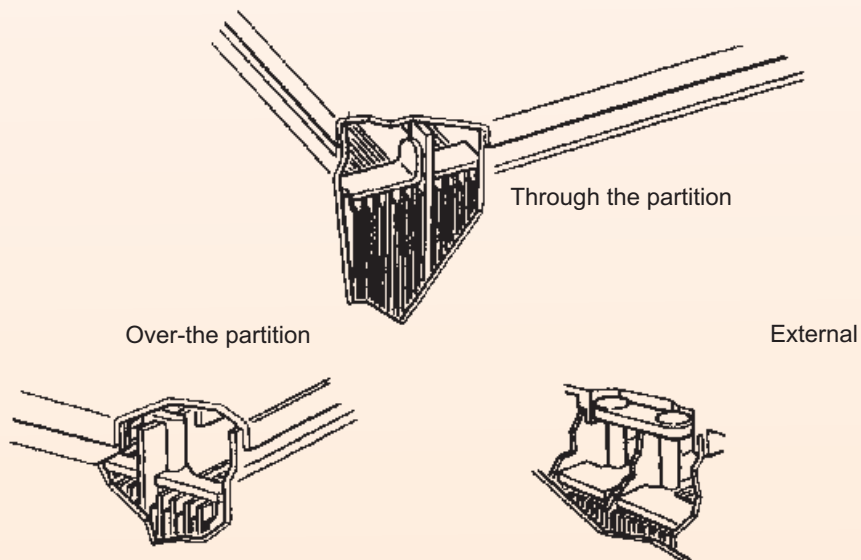


*Fig: Battery Case*

The case has partitions that separate the individual cell elements. Since each cell produces slightly over two volts, a twelve – volt battery requires six cells. Three cells make up a six-volt battery.

## Inter-cell connectors

Inter cell connectors are used to connect the cell elements in series that is, the positive strap of one cell in connected to the negative strap of the adjacent cell. Connections between the cells are either through the cell partitions in the case or over the top of the partition.



*Fig: Cell Connectors*

The connections are made before the cover is placed on the battery. This type of construction not only provides an acid-tight seal between the cells, but, also assures minimum voltage loss from cell to cell.

Of the three types of connections, the through the partition type, provides the shortest path between the cells, hence the lowest electrical resistance. The over the partition connector is slightly longer and thus offers more resistance. External connectors are the longest and offer the greatest resistance.

## Electrolyte

The one essential ingredient needed to complete the battery is the electrolyte. The electrolyte consists of sulfuric acid ( $H_2SO_4$ ) diluted with water ( $H_2O$ ), the ratio is about 35% acid to 65% water by weight. When an electrical load is connected to the terminals of a charged battery, the acid in the electrolyte reacts with the active materials on the plates and electricity is produced.

## Battery Cover

The battery cover is permanently bonded to the case. One piece covers are used with both through the partition and over the partition cell connectors.

## Battery Terminals

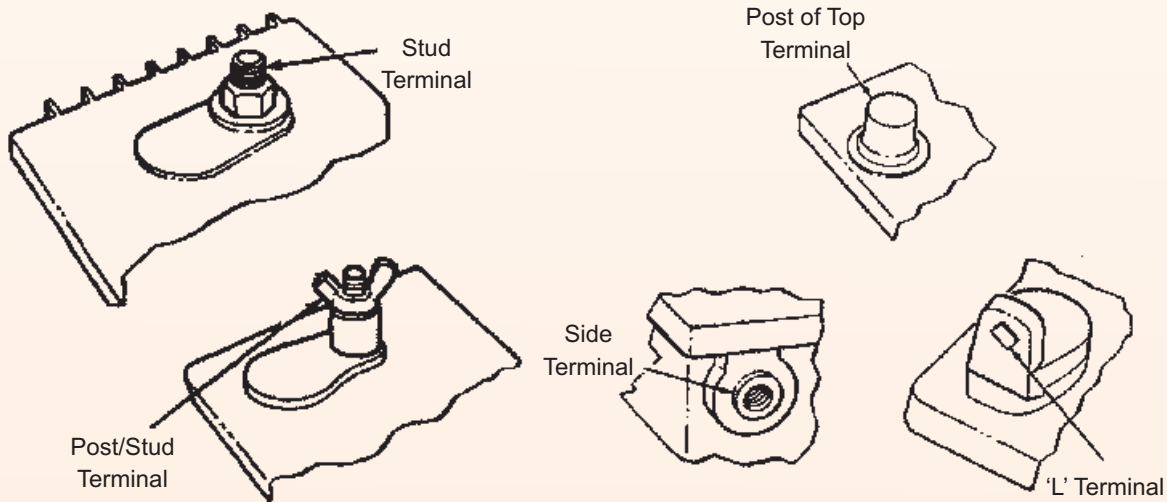


Fig: Heavy Duty Commercial Terminals

Fig: Common Terminals

The connecting terminals for the vehicle's electrical system are, with one exception, located on the cover. The following are the most common types of terminals :

- Post or top terminals, used on most car and truck batteries.
- Side terminals, which are positioned in the sidewall of the container near the top edge. These terminals are threaded and require a special bolt to attach the cables.
- L terminals, widely used on specialty batteries and on some import car batteries.
- Many heavy duty commercial applications use the familiar post terminals plus two additional types.

- ❖ Stud terminals, used frequently on heavy truck batteries.
- ❖ Combination post / stud terminals used on marine, golf cart and industrial motive power batteries.

## Battery Operation

- ❖ **When a battery is being discharged**, current flow from the negative pole to the positive pole. The hydrogen ions (H) of electrolyte (diluted  $H_2SO_4$ ) move to the positive plate and combine with oxygen (O) to form water. The sulphate ions ( $SO_4$ ) combine with lead to form lead sulphate ( $PbSO_4$ ). When the battery is fully discharged the specific gravity of electrolyte reaches to 1.160.
- ❖ **When a battery is being charged**, the current flows from the positive pole to the negative pole. The oxygen ions move to the positive plate where they displace the sulphate ions ( $SO_4$ ) simultaneously move back from the negative plates into the electrolyte. This turns the negative plates back into lead (Pb).

### Charge / Discharge cycle

In a fully charged cell, the active material of the positive plate is lead peroxide ( $PbO_2$ ). The negative plate contains pure lead (Pb) and the electrolyte is dilute sulphuric acid ( $H_2SO_4$ ).

When the cell discharges current, the electro chemical reaction changes the material of both plates to lead sulphate and weakens the electrolyte.

To recharge a cell, current is passed through it in the opposite direction to the discharge current. The chemical reaction described above is reversed, the positive and negative plates being reconverted to lead peroxide and lead respectively, and the electrolyte regaining strength as sulphate are given of from the recharged plates (See figure given below).

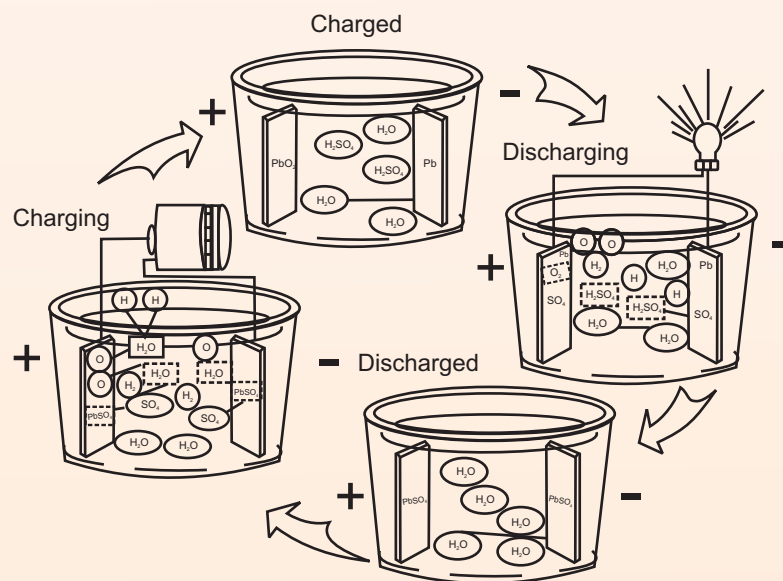


Fig: Battery Charge and Discharge Cycles – Conventional Battery

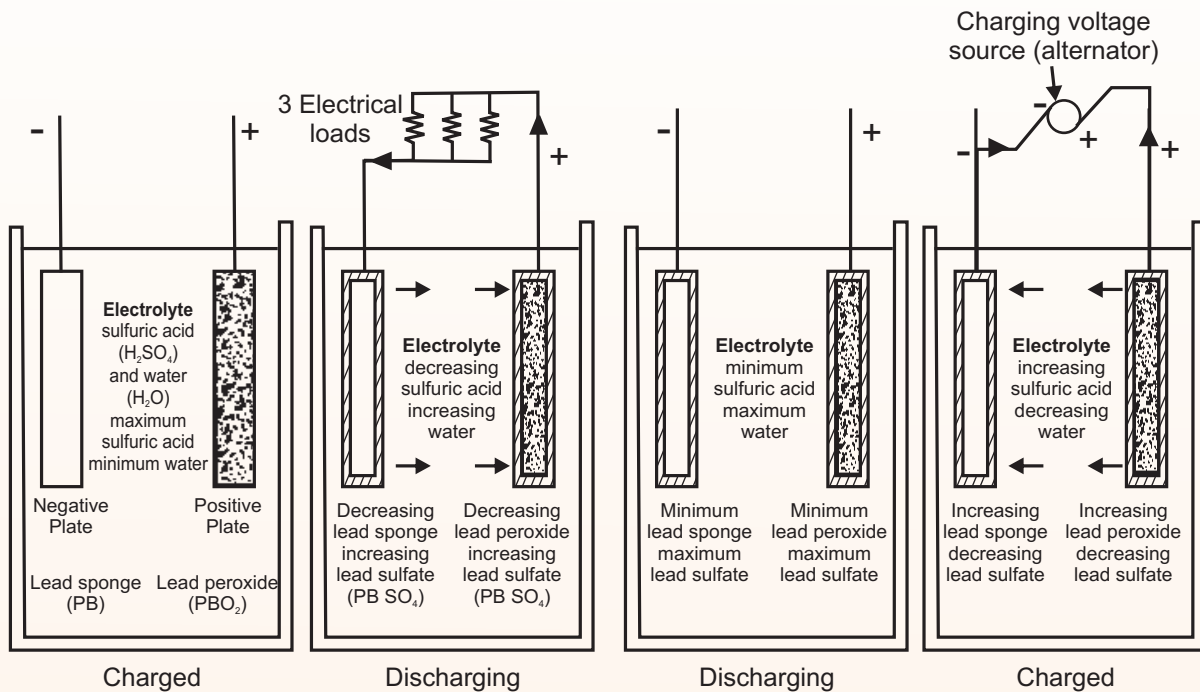


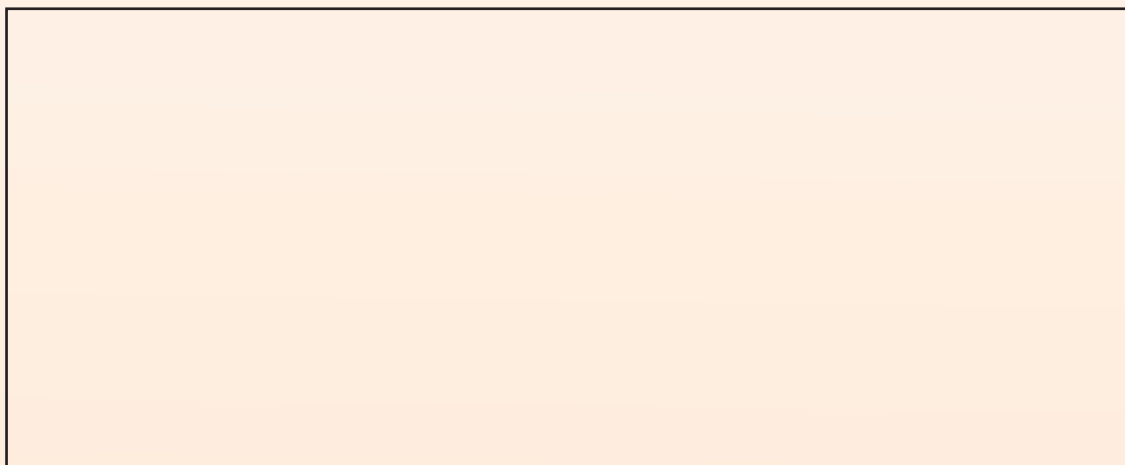
Fig: Battery electrochemical action from charged to discharged, and back to charged

## Exercise: Assignment

- List the different components of electrical system in a vehicle:

S.No.	Components

- Draw the photograph of battery and its components used in a vehicle:



### 3. Fill in the blanks:

- a) Battery is used for \_\_\_\_\_ a vehicle
- b) Electrical lights are used for \_\_\_\_\_.
- c) An automotive battery is an \_\_\_\_\_ device capable of producing electrical energy.
- d) Electrical energy is \_\_\_\_\_ by a chemical reaction between two \_\_\_\_\_ conductors (plates) that are immersed in an \_\_\_\_\_.
- e) The function of wind screen wiper is to \_\_\_\_\_ the wind screen.

### Checklist for Assessment Activity

Use the following checklist to see if you've met all the requirements for assessment activity.

#### Part A

- ❖ Role of electrical and electronic system in a vehicle.

#### Part B

Discuss in class the following:

- ❖ Importance of electrical and electronics system in automobiles.
- ❖ Use of battery in automobiles.
- ❖ Properties of a good battery.
- ❖ Care and maintenance of battery.

#### Performance standards/criteria covered by this assessment

Performance Standards	Yes	No
Able to identify electrical and electronic system of the vehicle.		
Able to identify and handle battery of a vehicle.		

### Suggested Reading

#### Books

Title	Author	Publisher
Automobile Engineering Vol I	Kirpal Singh	Standard Publishers
Automobile Engineering, Vol II	Kirpal Singh	Standard Publishers
Text Book of Automobile Engineering	R K Rajput	Laxmi Publications
Automobile Engineering	R K Singal	S. K. Kataria and Sons
Automobile Engineering Theory	Kapil Dev	Computech Publications
Automobile Engineering	K. M. Moeed	S. K. Kataria and Sons

## Websites

- auto.indiamart.com/auto-technology
- www.automobileindia.com/consumer-guide/automobile-technology
- auto.indiamart.com/auto-technology
- books.google.com/books/about/Automobile\_Engineering.html
- www.bikeadvice.org
- www.wikipedia.com
- auto.indiamart.com/auto-technology
- http://en.wikipedia.org/wiki/Airbag

## List of Contributors

1. Mr. Sunil K. Chaturvedi, CEO, Automotive Skills Development Council, Core 4-B 5<sup>th</sup> Floor India Habitat Centre, Lodhi Road, New Delhi - 110 003.
2. Mr. A.C. Deb, Sr. Lecturer, (Auto) - HOD, PUSA Polytechnic PUSA, New Delhi - 110012.
3. Mr. Vikas Gautam, S.B.V. NO.1, Morigate, Delhi - 110006.
4. Prof. A. P. Verma, Ex-Prof. & HOD, PSSCIVE, Bhopal.
5. Sh. Deepak Shudhalwar, Assistant Professor, E & T Division, PSSCIVE, Bhopal.
6. Dr. Saurabh Prakash, Associate Professor, E & T Division, PSSCIVE, Bhopal - Programme Coordinator.

# Unit-2

## Automobile Service Tools

### Introduction

As you know that that we require tools and equipment for servicing of a vehicle. Tools and equipment are used for repair and maintenance of any vehicle. Tools are made of different material as per strength, work and use. It can be easily handled and operated by any mechanic. Every vehicle has tools for emergency work as spare parts. The important tools used in automobile shops are general, electrical, special type.

Every tool has specific work and it is used in that way, Proper tools should be used for better efficiency. Generally every tool has various size and shapes. Tools should be properly handled and kept in their position. Tools should be regularly cleaned and washed at specific duration.

In this Unit, you will develop an understanding of the tools such as general, electrical, special and workshop machine used at automobile workshop.

### SESSION - 1: HAND TOOL

#### Relevant Knowledge

#### Hand Tool

A hand tool is a device for performing work on a material or servicing a two or four wheeler. The hand tools can be manually used employing force, or electrically powered, using electrical current.

Common tools used in servicing of a vehicle are as called as service tools like spanners, flies, pliers, grinders, drilling machine, oil and grease gun, hammer, mallet, screw drivers, wrench, chisel, pixes, hand hacksaw, Bench vice, Screw gauge, Vernier calipers, Multimeter, Caliper etc.



*Fig: Hand Tools*



## Identification and handling of general tools

The important hand tools used in automobile repairing shops are spanners, files, pliers, grinders, drilling machine, oil and grease gun, hammer, mallet, screw drivers, wrench, chisel, pikes, hand hacksaw, Bench vice etc. The hand tools are used for repair, maintenance of automobile wheelers. If you visit to any automobile shops/ two wheeler service station, observe the hand tools used by the technician/mechanics. Details of important hand tools are given here.

### Spanners

These are used to tighten and loosen nuts and bolts. These are made according to standard nut and bolt sizes. The Common spanners used are:

**Ring Spanners:** These are closed at both ends as they have full circular ring at ends. They do not slip and cause damage.



Fig: Ring Spanner close type



Fig: Open Ended Spanner

**Combination Spanners:** These are open at one end and close at other end.

**Box Spanners:** These are used to tighten nuts on drums of wheels. Sometimes they are also referred as wheel nut spanners. Figure shows different types of spanners used in motorcycle servicing and repairs.

**Open-ended Spanners:** These types of spanners are open from both side and used to tighten nut and bolts where low torque is required.

### Files

The files are hand tools used to perform wide variety of metal removal, tasks like removing of sharp edges, smoothing of surfaces, shaping of jobs, finishing, producing intricate shapes etc. The file has five parts: tang, heel, face, edge and point or tip. The file has hardened teeth,

when rubbed on the metal, perform cutting. Files are available in different shapes like hand, pillar, flat, square, three square, round, half round, knife edge, needle file are used as per job requirement.



*Fig: File*

## **Pliers**

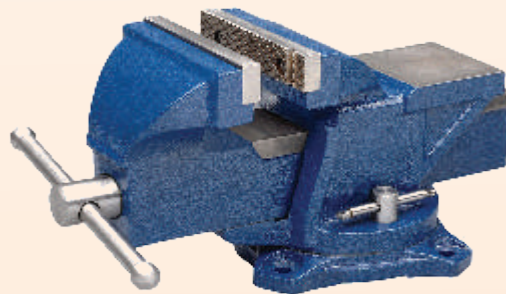
Pliers is used to hold small objects and either tighten or loosen parts into place. Pliers have several types which are all used by a mechanic in their work. Some pliers are also used for cutting work. The slip joint pliers are used for holding round and flat work pieces. Pliers are available in various shapes and sizes. Different types of pliers are shown here.



*Fig: Different type of pliers*

## **Bench Vice**

The vice is work holding device use to hold the work for operation like sawing, filing, chipping, tapping, threading, bending of small jobs, fitting etc. The vice consists of a body and two jaws, one of which is fixed and other is moveable. These jaws are fitted with hardened and serrated jaw plates for gripping the job. The size of the vice depends on the width of jaw.



*Fig: Bench vice*

## Hand Hacksaw

The hand hacksaw is a hand tool to cut the metals, which include steel sections like rod, angle iron, channel sections, sheets, pipes etc. It can also be used to cut the bolt heads and nuts during repair if these are jammed and do not open with wrenches or spanners. It is a simple hand tool and consists of handle, frame, blade and adjusting wing nut.



*Fig: Hack saw*

## Chisel

The chisels are hand tools for cutting, shearing and chipping of metals. The most widely used chisels are flat, cross cut, round nose and diamond point. The flat chisel is used to cut thin sheet metal, remove riveting heads, chip metal, split corroded nuts etc. Cross cut chisel narrow in width is used to cut key ways, narrow grooves, square corners and holes in sheet metal.



*Fig: Chisel*

## Screw Drivers

Screw drivers are tools often used by automobile mechanics to fit into screws and either tighten or loosen them into place. Screwdrivers have a distinct tip which fits into each screw. There are several different types of screwdrivers to fit each type of screw. This automotive tool actually has various types such as the Flat-head, Phillips, Robertson and hex which are all used by auto mechanics.



*Fig: Different type of screwdriver*

## Wrenches

The wrenches are hand tools for tightening and loosening of nuts and bolts. The function of this automotive tool is to hold slippery or small nuts and bolts and either loosen or tighten it.

There are two types of wrenches –adjustable and non-adjustable. The single end wrench is non-adjustable type and of which fits into one size of nut, bolt or head. The adjustable wrench is of adjustable type to fit into various sizes of nuts and bolts. These are useful particularly for loosening and tightening of odd size nuts and bolts.



Fig: Different type of wrenches (adjustable)

## Hammers

The hammers are general purpose workshop hand tools used for straightening of sections, riveting, striking of nails, inserting the components by striking, inserting key ways and fitting by striking. The hammer consists of head made from hard and tempered steel and wooden handle. The head has a flat striking surface known as a face and the other end is called pein. The peins are of different shapes such as ball pein, cross pein and straight pein. The hammers made of hardened steel are known as engineers hammers and are usually used for working with steel components.



Fig: Hammer

## Snips

The snips also called shears are used to cut sheet metals to the required shapes. The main parts of the snips are cutting blades which are hard and ground to sharp edge and handle.



Fig: Snip

## Mallet

A mallet is a kind of hammer, usually of rubber or wood smaller. Mallets are used when a softer blow is called for than that delivered by a metal hammer. They are typically used to form sheet metal, since they don't leave marks, as well as for forcing tight-fitting parts together.



*Fig: Mallet*

## Grease Gun

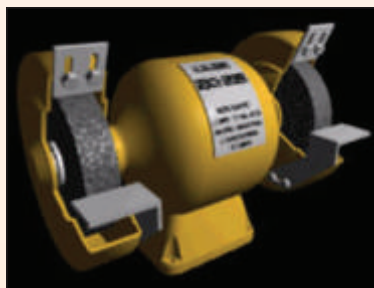
A grease gun is a common workshop and garage tool used for lubrication. The purpose of the grease gun is to apply lubricant through an aperture to a specific point, usually on a grease fitting. The channels behind the grease nipple lead to where the lubrication is needed.



*Fig: Grease gun*

## Grinding Machine

It is also known as grinder. It is a type of machining using an abrasive wheel as the cutting tool. Grinding is used to finish work pieces which must show high surface quality (e.g., low surface roughness) and high accuracy of shape and dimension.



*Fig: Grinding Machine*

## Drill Bits

Drill bits are cutting tools used to create cylindrical holes. Bits are held in a tool called a drill, which rotates them and provides torque and axial force to create the hole. Specialized bits are also available for non-cylindrical-shaped holes.



*Fig: Drill bits*

## **Punch**

A punch is a hard metal rod with a shaped tip at one end and a blunt butt end at the other, which is usually struck by a hammer. Punches are used to drive objects, such as nails, or to form an impression of the tip on a work piece. Decorative punches may also be used to create a pattern or even form an image.



*Fig: Punch*

## **Wheel Wrenches**

These wrenches are designed for opening for wheels of vehicle. It helps a person to open wheel.



*Fig: Wheel wrenches*

## **Tool Box**

Tool box is box used for keeping all the tools. Box contains number of compartments in which different tools systematically.



*Fig: Toolbox*

## Handling, Care & Maintenance of General Tools

General tools should be properly handled and a proper procedure should be adopted. Tools should be kept at proper place after use. Worn out tools should be replaced with new tools. Tools should be kept in the toolbox or display board. Tools should be handled properly. Correct procedure should be used for holding any tools, otherwise it may hurt worker or material. Proper safety procedure should be adopted. Proper dress should be wear by trainees during workshop practical.

### Exercise: Assignment

1. List the general tools:

S.No.	Name of Tools

2. Prepare a poster showing tools used in automobiles:

3. A. Fill in the blanks:

- a) Hammer is used for \_\_\_\_\_.
- b) A grease gun is a \_\_\_\_\_ tool used for lubrication.
- c) The wrenches are \_\_\_\_\_ for tightening and loosening of nuts and bolts.
- d) Pliers is used to \_\_\_\_\_ small objects and either \_\_\_\_\_ or loosen parts.

B. Tick the correct answer

1. Mallet is made of

- a) Iron
- b) Wood
- c) Steel
- d) Aluminum

**2. A spanner is used for**

- a) Tightening the bolt
- b) Opening the nut
- c) Cutting the nut
- d) Folding the nut

**3. Tool box is used for storing**

- a) Tools
- b) Oil
- c) Water
- d) Spare parts

### Checklist for Assessment Activity

Use the following checklist to see if you've met all the requirements for pollution control.

**Part A**

- ❖ Share importance of tools used in workshop.

**Part B**

Discuss in class the following:

- ❖ What is meaning of hand tools?
- ❖ What are the different types of tools used in automobile?
- ❖ Differentiate between spanner and wrench, hammer and mallet?
- ❖ Name two popular tools used in as spare parts in motorcycle.
- ❖ Write the importance of tool box.

**Performance standards/criteria covered by this assessment**

Performance Standards	Yes	No
Able to explain importance of hand tools		
Able to identify hand tools		

## SESSION - 2: MEASURING TOOLS

### Related Information

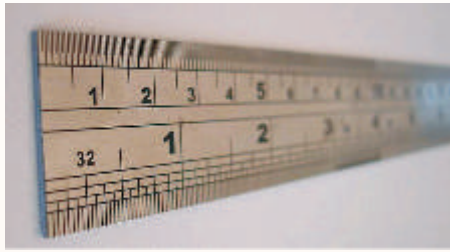
#### Measuring Tools

Measuring tools are important tools in automobile workshop. It helps mechanic to measure the sizes and dimensions of various components of automobile. Measuring tools are commonly used. Auto mechanic should know the use and handling of these tools. Important measuring tools are steel rule, caliper, multi meter, screw gauge, multi meter, hydrometer etc.

#### Steel Ruler

A steel ruler is an instrument used in geometry, technical drawing, printing and engineering/building to measure distances and/or to rule straight lines. Metal is used for more durable rulers for use in the workshop.

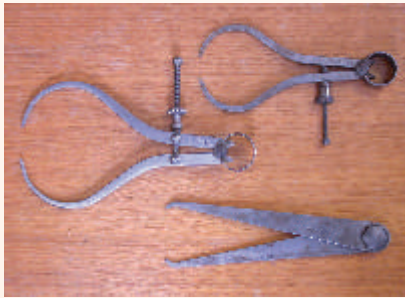




*Fig: Steel Ruler*

## Caliper

A caliper is a device used to measure the distance between two opposing sides of an object. The tips of the caliper are adjusted to fit across the points to be measured, the caliper is then removed and the distance read by measuring between the tips with a measuring tool, such as a ruler. It is used in many fields such as mechanical engineering, metalworking, woodworking, science and medicine.



*Fig: Outside Calipers*



*Fig: Inside Calipers*

## Screw gauge (Micro meter)

Screw gauge is a device incorporating a calibrated screw used widely for precise measurement of small distance. Micrometers are often, but not always, in the form of calipers. Micrometers use the principle of a screw to amplify small distances that are too small to measure directly into large rotations of the screw that are big enough to read from a scale.

Screw gauge are used measuring tools. These tools give proper measurement. Proper handling and use is important in measuring any dimension.



*Fig: Screw gauge*

## Exercise: Assignment

1. List the measuring tools:

S.No.	Name of Measuring Tools

2. Prepare a poster of measuring tools used in automobile:

3. Fill in the blanks:

- a) Outside caliper is used for \_\_\_\_\_.
- b) Scale measures is used for \_\_\_\_\_.
- c) Screw gauge is a \_\_\_\_\_ incorporating a calibrated screw used widely for precise \_\_\_\_\_ of small distance.

## Checklist for Assessment Activity

Use the following checklist to see if you've met all the requirements for pollution control.

### Part A

- ❖ Share importance of measuring tools

### Part B

Discuss in class the following:

- ❖ What are uses of measuring tools?
- ❖ Why screw gauge is used?
- ❖ List the measuring tools used in automobile shop.
- ❖ Differentiate between outside calipers and inside calipers.

## Performance standards/criteria covered by this assessment

Performance Standards	Yes	No
Able to explain measuring tools		
Able to discuss about advantages and use of various measuring tools		

## SESSION - 3: ELECTRICAL TOOLS

### Relevant Knowledge

Electrical tools are used for measuring and testing current, voltage etc. These tools are operated with battery or power. It helps mechanic to check and measuring the current, voltage of electrical component etc. Common electrical tools used are multi meter, ammeter, volt meter etc. Many electrical measuring tools are available in the workshop and same can be seen and discussed during the visit to a service centre of a vehicle.

### Multi Meter

A multimeter or a multi tester, also known as a VOM (Volt-Ohm meter), is an electronic measuring instrument that combines several measurement functions in one unit. A typical multi meter may include features such as the ability to measure voltage, current and resistance. A multi meter can be a hand-held device useful for basic fault finding and field service work or a bench instrument which can measure to a very high degree of accuracy. They can be used to troubleshoot electrical problems in a wide array of industrial and household devices such as electronic equipment, motor controls, domestic appliances, power supplies, and wiring systems.



Fig: Multimeter

### Tachometer

A tachometer is an instrument that measures the working speed of an engine. It is mostly used to measure engine speeds of road vehicles in revolutions per minute. The word comes from two Greek words, tachos "speed" and metron, "to measure". The engine speed is displayed on the tachometer on a calibrated analogue dial.



Fig: Hydrometer

### Hydrometer

A hydrometer is an instrument used to measure the specific gravity (or relative density) of liquids; that is, the ratio of the density of the liquid to the density of water.

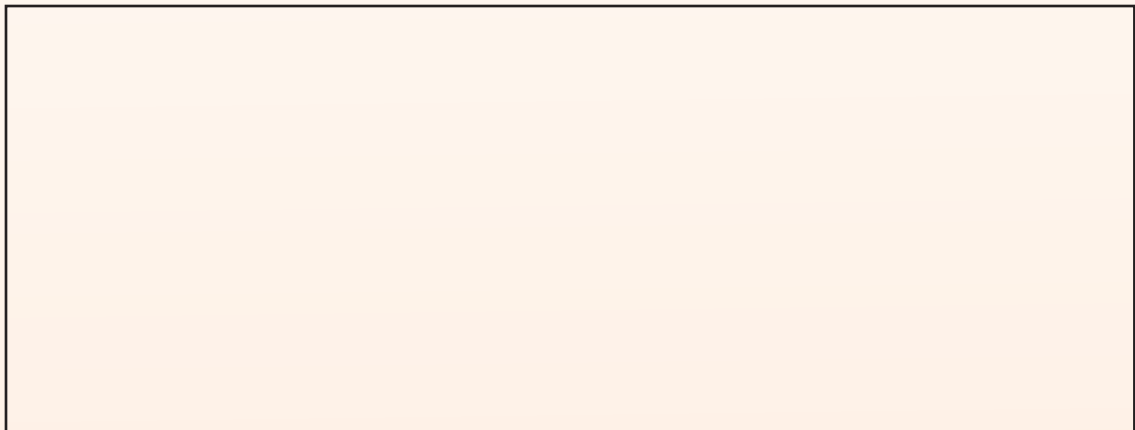
A hydrometer is usually made of glass and consists of a cylindrical stem and a bulb weighted with mercury or lead shot to make it float upright. The liquid to be tested is poured into a tall container, often a graduated cylinder, and the hydrometer is gently lowered into the liquid until it floats freely. The point at which the surface of the liquid touches the stem of the hydrometer is noted. Hydrometers usually contain a scale.

### Exercise: Assignment

1. List the electrical tools:

S.No.	Name of Electrical Tools

2. Observe and identify two types of electrical tools in service centre and draw their diagrams:



3. A. Fill in the blanks:

1. A multimeter or a multi tester, also known as a \_\_\_\_\_.
2. Tachometer is used for \_\_\_\_\_.
3. A hydrometer is usually made of \_\_\_\_\_.

- B. Tick the correct answer

Multimeter is used for measuring

- |             |            |
|-------------|------------|
| a) Speed    | b) Current |
| c) Distance | d) Height  |

### Checklist for Assessment Activity

Use the following checklist to see if you've met all the requirements for tools.

## Part A

- Share importance of measuring tools.

## Part B

Discuss in class the following:

- Role of electrical measuring tools.
- Distinguish between hydrometer and ammeter.
- Handling and operation of a multimeter.

### Performance standards/criteria covered by this assessment

Performance Standards	Yes	No
Able to Identify electrical measuring tools		
Able to handle and operate multimeter		

## SESSION - 4: SPECIAL TOOLS

### Related Knowledge

Every vehicle has large number of parts which are used in assembling the vehicle. During disassembly of these parts are operated by special tools. Special tools are important tools used for special purpose. These tools are special in nature and does the special purpose work. Use of these tools makes work easy and save time. These tools are costly and available in authorized service centre.

With the use of special tools, the life of parts increases and damage is reduced. These tools are designed for special work. Handlings of these tools are important. Proper care should be taken while operating and handling these tools.

During visit to the garages student should see and observe the functioning of tools.

Some of common special tools are Universal holder, socket wenches, flywheel puller, tappet cover wrench, Pierce plier, piston slide base, socket, front, fork oil seal driver, driver outer, ball race driver, tappet cover wrench. etc. We will discuss some special tools here.

### Universal clutch holding tool

This universal clutch holding tool is tool for holding the compressor clutch when removing or installing the center nut.

### Torque wrench

A torque wrench is a tool used to precisely apply a specific torque to a fastener such as a nut or bolt. It is usually in the form of a socket wrench with special internal mechanisms.

### Tappet Wrench

A wrench having parallel jaws at fixed separation (often on both ends of the handle).



## Flywheel puller

A proper flywheel puller is the only correct and safe way to remove a flywheel from engine. Without using the recommended tool, there are chances of damaging the flywheel which could lead to a potential reliability issue.



Fig: Flywheel puller

## Exercise : Assignment

1. List the reasons for using special tools:

S.No.	List of Reasons

2. Prepare a poster showing figure of special tools:

3. Fill in the blanks:

- a) Special tools is used for \_\_\_\_\_.
- b) Hydrometer is used for measuring \_\_\_\_\_.
- c) Hammer and mallet is used for \_\_\_\_\_.
- d) Tools help mechanic in \_\_\_\_\_ of two wheeler.
- e) Multimeter is used for measuring \_\_\_\_\_, \_\_\_\_\_ and \_\_\_\_\_.

## Checklist for Assessment Activity

Use the following checklist to see if you've met all the requirements for special tools.

## Part A

- Share importance of special tools

## Part B

Discuss in class the following:

- Write the importance of special tools.
- Why hydrometer is used?
- List the special tools used in automobile sector.
- Write the purpose of torque wrench used.

### Performance standards/criteria covered by this assessment

Performance Standards	Yes	No
Able to explain special tools		
Able to discuss about advantages and use of various special tools		

## SESSION - 5: SERVICE WORKSHOP EQUIPMENT

### Related Knowledge

Modern service workshop deploy important workshop machine for handling and servicing of a vehicle. These machines make work very systematic and comfortable to mechanic. Common equipment fitted in the workshops are Two Post lift, Air compressor, Wheel balancer, Bench vice, Work tables, Bench grinder, Oil draining & Filling equipment, Cooling system tester, BC clamp meter, Coolant tester, Battery & Charging system tester (Megatronics), Diagnostic tool (genesis Evo), Pneumatic tools and many other tools. We will be discussing some equipment here. Whenever you visit any service centre, kindly see the working of these machines.

### Two Post Lift

It is used for lifting an automobile vehicle and to carry out the work under the chassis. It consists of two columns and screws are fitted in each column. Similarly four post lift is also used in workshop.



Fig: Two Post Lift

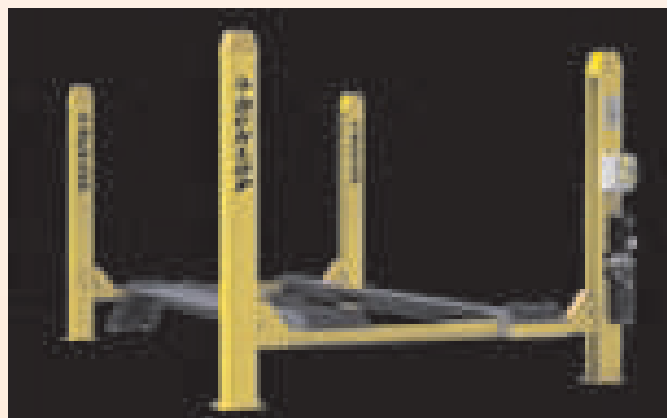


Fig: Four Post Lift

## Air compressor

This is the machine which is used to increase the pressure of air by reducing its volume.

Generally air compressors have been categorized in two types:

- ❖ Rotary Screw Air Compressors
- ❖ Reciprocating Air Compressors

## Rotary Screw Air Compressors

The rotary screw air compressor has become the most popular source of compressed air for industrial applications.

## Reciprocating Air Compressors

Designed for heavy shop or industrial use, Ingersoll Rand Two Stage electric air compressors provide the quality and performance that are ideal for most applications and users, including automotive service and body shops, fleet maintenance, machine shops, production and manufacturing lines, car washes, maintenance/ repair shops and farms.

## Wheel balancer

Wheel balancing helps in minimizing tire vibration and bounce. By wheel balancing traction, steering control improves and life of tires increases. Automatic wheel balancer is designed for the tyre shop and workshop. It is very simple and easy to operate.



Fig: Wheel balancer



Fig: Wheel Balancer

## Pneumatic wrenches

Pneumatic wrenches that is made from premium quality raw material. This type of wrenches are used for accuracy and easy operations, mostly in workshops, power plants, mining & cement industries, railways industries, fertilizers/ chemicals and so on. These are used where accurate torque is required on a nut and bolt. These wrenches are operated electrically.





Fig: Pneumatic wrenches

### Exercise : Assignment

1. List the reasons for using workshop equipment:

S.No.	List of Reasons

2. Prepare a poster showing uses of workshop equipment:

3. Fill in the blanks:

- a) Pneumatic wrench is used for \_\_\_\_\_.
- b) Two Post lift help mechanic to work under \_\_\_\_\_.
- c) Wheel balancer work for \_\_\_\_\_.

## Checklist for Assessment Activity

Use the following checklist to see if you've met all the requirements for Service Workshop Equipment.

### Part A

- ❖ Share importance of Service Workshop Equipment.

### Part B

Discuss in class the following:

- ❖ Why is necessary to go to Service Workshop?
- ❖ Important Service Workshop Equipment used in workshop.
- ❖ Differentiate between pneumatic and common manual wrench.
- ❖ Differentiate between Rotary and Reciprocating compressor.

### Performance standards/criteria covered by this assessment

Performance Standards	Yes	No
Able to explain Service Workshop Equipment		
Able to discuss about Service Workshop Equipment		

## Suggested Reading

### Books

Title	Author	Publisher
Automobile Engineering Vol I	Kirpal Singh	Standard Publishers
Automobile Engineering, Vol II	Kirpal Singh	Standard Publishers
Text Book of Automobile Engineering	R K Rajput	Laxmi Publications
Automobile Engineering	R K Singal	S. K. Kataria and Sons
Automobile Engineering Theory	Kapil Dev	Computech Publications
Automobile Engineering	K. M. Moeed	S. K. Kataria and Sons
Automobile Engineering	GBS Narang	Khanna Publisher Delhi
Automotive Mechanic	S Srinivasan	TATA MacgraHill Pub. New Delhi

### Websites

- ❖ [auto.indiamart.com/auto-technology](http://auto.indiamart.com/auto-technology)
- ❖ [www.automobileindia.com/consumer-guide/automobile-technology](http://www.automobileindia.com/consumer-guide/automobile-technology)
- ❖ [auto.indiamart.com/auto-technology](http://auto.indiamart.com/auto-technology)
- ❖ [books.google.com/books/about/Automobile\\_Engineering.html](http://books.google.com/books/about/Automobile_Engineering.html)

- > [www.bikeadvice.org](http://www.bikeadvice.org)
- > [www.wikipedia.com](http://www.wikipedia.com)
- > [www.ipertools.in](http://www.ipertools.in)
- > [www.autoservindia.com](http://www.autoservindia.com)
- > [en.wikipedia.org](http://en.wikipedia.org)

### List of Contributors

1. Mr. Sunil K. Chaturvedi, CEO, Automotive Skills Development Council, Core 4-B 5<sup>th</sup> Floor India Habitat Centre, Lodhi Road, New Delhi - 110003.
2. Mr. A.C. Deb, Sr. Lecturer, (Auto) – HOD, PUSA Polytechnic PUSA, New Delhi -110012.
3. Mr. Vikas Gautam, S.B.V. NO.1, Morigate, Delhi - 110006.
4. Prof. A. P. Verma, Ex-Prof. & HOD, PSSCIVE, Bhopal.
5. Sh. Deepak Shudhalwar, Assistant Professor, E & T Division, PSSCIVE, Bhopal.
6. Dr. Saurabh Prakash, Associate Professor, E & T Division, PSSCIVE, Bhopal - Programme Coordinator.

# Unit-3

## Vehicle Servicing

### Introduction

When you get up in the morning and clean your face and body regularly, it makes you feel fresh. You use soap, shampoo, and detergent for cleaning. Similarly, a vehicle requires a cleaning operation. Cleaning of vehicles is very important. It makes the vehicle look better and gives comfort to the driver and passengers. We have to change the oil, lubricant and coolant of a vehicle whenever its quality is disturbed. We have to properly check all the important components of a vehicle.

In this Unit, you will develop an understanding of the methods of washing car, procedure for changing of oil, coolant, lubricants, air and water filter of a vehicle, so that the efficiency of a vehicle increases.

### SESSION - 1: WASHING OF A VEHICLE

#### Relevant Knowledge

We see in the picture that a person is washing the vehicle by cloth. It is a common practice in our country. We may call the person cleaning a vehicle, car wash wala. He comes in the morning to your house, collects the keys of your vehicle and cleans the car. Generally this person keeps two type of cloths with himself first one is dry and other one is wet. Dry cloth is used first for removing dust and the wet cloth is used for cleaning. You can see in these photographs, a carwash wala is manually cleaning the vehicle.



Fig: Manual car washing

#### Proper steps for manually cleaning a vehicle

We will learn here the step by step practice to be followed while washing a vehicle ourselves

- ❖ It is suggested that a shady spot should be chosen, preferably away from trees so that the car doesn't get leaves etc.
- ❖ All the doors and windows should be closed.

- Take a bucket of clean water and pour one full spoon of car soap.



*Fig: Manual car washing*

- Remove the dirt from the car, starting at the roof and getting down to the tyres.
- Take a sponge or terry cloth piece in the bucket of soapy water and sponge the roof of the car.
- Spray off excess soap when the entire roof has been cleaned.



*Fig: Manual car washing*

- Clean the tyre sidewalls with a plastic brush.
- Clean the car with the water pipe properly, so that, there is no soap or dirt spot.
- Take an old towel and dry the car thoroughly by setting the towel flat against the surface of the car and dragging it along the surface to pick up any water spots. Start from the roof and work your way down to the tyres.

- ❖ For cleaning the windows use pieces of newspaper on both the inside and the outside of the windows. Rub and clean metal or chrome parts so that there are no water spots.



Fig: Car washing with cloth

### Precautions during washing

- ❖ Wear old clothes for this job.
- ❖ Soap dries fast. Wash one side at a time to keep the soap from drying on your car's paint.
- ❖ Wet and wring out your clothes before you dry, it will absorb water better.
- ❖ Do not use detergent, dish soap. Detergent, dish soap is designed for dishes. Use car wash soap only.

### Washing at a Service Station

Similarly, a vehicle is also washed at service station or a car wash station. The service stations use automatic washing unit in which procedure of washing takes place. In an automatic washing unit, cleaning as well as shampoo washing takes place. You can view here a photo of automatic washing unit. You may plan a visit to nearest car service station and observe how the washing of a vehicle is taking place. You may see that water is sprayed on the car with the help of mist sprayer. Brushes are used for cleaning the body of a vehicle.

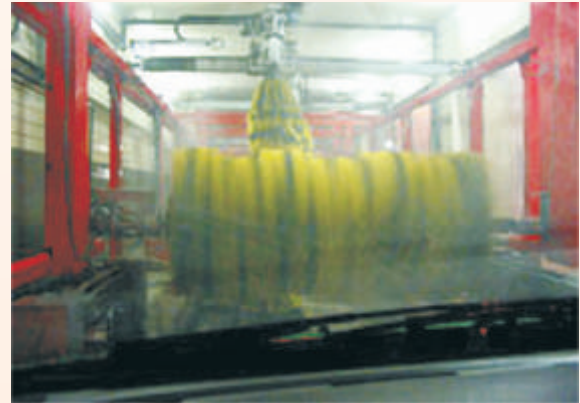


Fig: Automatic car washing unit

### Exercise: Assignment

- List the steps used in manual washing:

S.No.	Steps Used

2. Prepare a poster showing steps used in car washing of a vehicle:

3. Fill in the blanks:

- a) \_\_\_\_\_ is used for cleaning the vehicle.
- b) Detergent, soap powder should \_\_\_\_\_ be used while washing a vehicle.
- c) Start cleaning from the roof and work your way \_\_\_\_\_ to the tyres.
- d) For cleaning the windows use pieces of \_\_\_\_\_ on both the inside and the outside of the windows.
- e) Service stations use automatic washing unit in which \_\_\_\_\_ the operation of washing takes place.

### Checklist for Assessment Activity

Use the following checklist to see if you've met all the requirements for washing of a vehicle.

#### Part A

- Share importance of washing of a vehicle.

#### Part B

Discuss in class the following:

- Why vehicle washing is necessary?
- What are the steps to be followed for manual washing of a vehicle?

#### Performance standards/criteria covered by this assessment

Performance Standards	Yes	No
Able to explain importance of washing		
Able to list general steps during washing		



## SESSION - 2: CHANGING OF OIL AND OIL FILTER

### Relevant Knowledge

As you know, engine oil is an important material in a vehicle. Incorrect oil levels can cause serious damage to your vehicle's engine, so it's important to check the oil level regularly. This is very easy to do and just takes a few minutes. It is recommended always to keep a 1 litre bottle of oil in your car so that you can top up whenever necessary.

### How to check the oil?

First, choose the right oil for your vehicle or car by checking your vehicle manufacturer's recommendation.



Ensure that your car is parked on level ground, with the hand brake on and the engine off. Open the bonnet with the help of a lever under the dashboard and keep it open with its support. Avoid touching the hot engine. Allow one minute for the oil to settle.



Put on some protective gloves and pull out the dipstick. Wipe it clean with a paper towel and replace it fully for several seconds. Then remove it again to study the oil level.



The oil level should fall somewhere between the minimum and maximum marks on the dipstick and may need topping up. See the diagram for an indication of how much oil to add.





Remove the oil filter cap to top up the engine with the appropriate amount of oil, preferably using a funnel. The scale on the bottle will indicate how much has been used. Repeat steps 2 and 3 to check the new level.



Replace the dipstick and the oil filler cap securely. Clean any finger marks from the bonnet and wipe any oil from your hands with a moist towel, disposing of any waste materials in an appropriate place.

When you notice that your oil level is below the minimum mark, find out how many kilometers have passed since the last oil change. If you're not sure, refer to your handbook for recommended oil-change intervals or if your mileage is above 15000 kms, it's advisable to perform a complete oil change. If the mileage is between 4000kms and 15000 kms you will only need to top up your oil. You may see the vehicle service manual and find the recommended time or distance for changing of oil regularly, so that you can keep your car running well. Over time your oil breaks down and your filter becomes clogged with contaminants. Fortunately, changing your oil is both easy and inexpensive. You will learn it in this section.

### How to change the engine oil yourself?

Changing your car oil is easier than it sounds and could also save you money in the long term. It shouldn't take longer than 45 minutes – just make sure that you follow your manufacturer's specific instructions and safety directions. Firstly, choose the ideal oil for your car from the market as per recommendation of the manufacturer.

#### Material and tools requirement for changing of the oil.

- Engine Oil (4 or 5 litres – check the vehicle's service manual)
- New oil filter - check vehicle's service manual
- Safety glasses and rubber gloves
- Plastic container and funnel
- Car jack and jack stands

- Drain plug socket wrench
- Paper towels and a rag
- Oil filter wrench

### What you have to do?

#### 1. Prepare your car

The car should be on a level surface with the parking brake on and engine off, leaving the oil to cool for a few minutes. If you need space under the car, jack it up and use jack stands to support it. Jacks on their own are very unstable – never get under your car without using jack stands. You could also put something underneath the engine to prevent spilling oil onto the ground.

#### 2. Unscrew the oil cap

Locate the oil cap (check with the manual to locate it) and unscrew it. This is very important, as a vacuum will not allow all the oil to drain out.

#### 3. Locate the oil drain plug

Get underneath the car and locate the oil drain plug. This is a lone bolt at the bottom of the oil sump.

#### 4. Place the container

Place a container big enough to hold the oil beneath the oil drain plug and unscrew the plug, being careful not to let it fall into the container. Do not come in contact with the oil – it can be extremely hot.

#### 5. Drain out the old oil

Allow all the oil to drain out. This can take several minutes.

#### 6. Locate the oil filter

Locate the old oil filter with the help of your car's service manual. It should be identical to the one you are replacing it with.

#### 7. Remove the old oil filter

Turn the filter wrench anti-clockwise to loosen the oil filter. The filter may be full of oil so take care not to spill any.

#### 8. Prepare the new filter

Clean up the filter seat on the engine and place a light coating of oil on the gasket of the new filter.

#### 9. Install the new filter

Carefully screw the new filter into place by hand, making sure it is not overtight. Screw back in the oil drain plug and tighten it with the wrench.

### 10. Fill up with oil

Using the funnel, carefully fill the engine oil, avoiding spillages. Measure the oil level with the dipstick after every two litres filled.



Fig: Fill up oil with funnel

### 11. Check the level is correct

When oil has reached the correct level, replace the oil cap. Turn on the engine for ten minutes and then off again. Check the oil level with the dipstick once again - if the level is low, add more oil.

### 12. Clean up

Clean up all oil spillages on your engine and check for any leaks from the drain plug.

### 13. Properly dispose of the old oil and filter

Used oil is highly toxic and must never be disposed off with domestic waste. It's illegal to pour used oil into the sewage network. Put the used oil in a sealed container and label it. Then take it to an auto repair centre, service station or recycling centre. Most places will accept used oil for free.

## Exercise: Assignment

### 1. List the tools required for changing of oil:

S.No.	Name of Tools

### 2. Prepare a poster showing tools used in changing of oil:

### 3. Fill in the blanks:

- Follow vehicle manufacturer's specific \_\_\_\_\_ and safety directions.
- Choose the ideal oil for your car from the market as per \_\_\_\_\_ of manufacturer.
- Highly toxic oil must \_\_\_\_\_ be disposed of with \_\_\_\_\_ waste.
- Car should be on a \_\_\_\_\_ surface with the \_\_\_\_\_ brake on and engine \_\_\_\_\_.
- Changing of car's engine \_\_\_\_\_ and \_\_\_\_\_ is one of the most important things.

### Checklist for Assessment Activity

Use the following checklist to see if you've met all the requirements changing of oil and oil filter.

#### Part A

- Share importance of changing of oil and oil filter

#### Part B

Discuss in class the following:

- Why oil changing is important?
- What are the different types of tools used in changing oil and oil filter? Steps used in oil replacement process.

#### Performance standards/criteria covered by this assessment

Performance Standards	Yes	No
Able to explain importance of oil replacement		
Able to identify general steps followed in oil replacement		

## SESSION - 3: CHANGING OF AIR FILTER

### Relevant Knowledge

You know that any vehicle needs air just as much as it needs fuel. Air filters keep the inside of the engine free of dust and insects. Replacing or cleaning air filter at the recommended interval to keep air flowing freely helps the car run well. Air filters are inexpensive and quick to replace, so we can do this routine maintenance with ourselves.

### Material and Tools Requirement for the changing of air filter

- A new air filter/ specifications as recommended by the manufacturer.
- A flat screwdriver.
- A Phillips screwdriver.
- A compressor air valve w/hose.

## Steps

**Obtain the correct replacement filter:** It should be the same as the one you will replace. Consult your vehicle service manual or auto parts store if you need assistance finding the right part.

**Secure the vehicle:** Park the car on level ground and apply the parking brake. Shift into first gear (manual transmission) or Park (automatic transmission) and turn off the ignition.

**Open the bonnet (hood):** Release the bonnet with the lever inside the car. Move the exterior bonnet catch for final release. Lift the bonnet and secure it with the prop rod.

**Locate the air filter:** Air filter is located on the top of engine.

**Remove the air filter cover:** Loosen the hose clamp that seals the air conduit. Undo all the screws holding the air filter cover. Some models have wing nuts, other air filters are just clamped on with a quick release system. Keep screws and other parts together and in a safe location so you can find them later. Pull the cover out of the air conduit and lift it up so it comes off the lower part of the housing.

**Take out the air filter:** Now you can see a round or rectangular filter made of cotton, paper or gauze. Filters have a rubber rim that seals off the unit's interior. Simply lift the filter out of the housing.

**Clean the air filter housing:** Connect the air hose to the compressor and use the compressed air to blow out the dust, or use a vacuum cleaner to suck up any dirt.



*Fig : Cleaning of air filter housing*

Seal the air conduit with removable adhesive tape. It only takes a minute and that way you won't get any dirt into the engine whilst cleaning.

**Replace the filter:** Replace the old filter with a new one. Simply insert it into the housing with the rubber rim facing up. Make sure the edges are sealed by the rubber rim.

**Replace the cover:** Carefully insert the cover back into the air conduit and then press the entire.

**Replace the cover:** Carefully insert the cover back into the air conduit and then press the entire piece down onto the lower half of the air filter unit. Make sure it's on straight and securely, otherwise you could alter the engine's performance. Tighten all the screws or clamps and

recheck that you have put everything firmly back together by rocking the unit gently with both hands. Shut the bonnet securely.

Check the filter regularly to keep your car breathing at maximum efficiency by keeping the dust out.

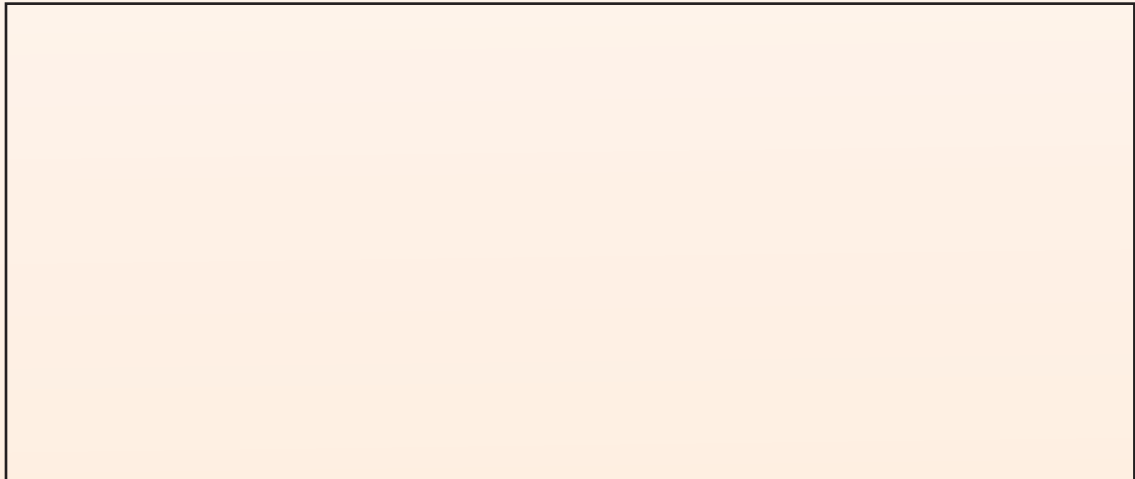
**Change the filter every 50,000 km or about once a year:** If you drive in a dusty area, it will need replacement more often. Your vehicle's service manual or periodic maintenance guide should have recommendations for your car. You can clean the old filter as long as the material isn't torn, cracked or oil stained. Use a light to check if it is oily inside. Hold a lamp behind it and see if the light gets blocked out by oil. Proceed, if the light can be seen. Now, blow out the dust with compressed air if you have it, or else vacuum it up. Turn the air filter around to clean both sides. If you choose to clean the filter, you can put the filter back in this time, but buy yourself a new filter soon and change at the next check.

## Exercise: Assignment

1. List the tools used in changing of air filter:

S.No.	Name of Tools

2. Prepare a poster showing air filter used in automobiles:



3. A. Fill in the blanks:

- a) Air filter is used for \_\_\_\_\_.
- b) Air filter is a \_\_\_\_\_ used for \_\_\_\_\_.
- c) Air filter should be changed at \_\_\_\_\_ km.
- d) Air filters are \_\_\_\_\_ and \_\_\_\_\_ to replace.

**B. Tick the correct answer:**

1. Air filter is made of
  - a) Iron
  - b) Wood
  - c) Steel
  - d) Paper
2. Air filter is cleaned by
  - a) Chemical
  - b) Air Blower
  - c) Oil
  - d) Water

**Checklist for Assessment Activity**

Use the following checklist to see if you've met all the requirements for pollution control.

**Part A**

- Share importance of air filter used in vehicle.

**Part B**

Discuss in class the following:

- Why air filter is important?
- What are the different steps used in changing of air filter.

**Performance standards/criteria covered by this assessment**

Performance Standards	Yes	No
Able to explain importance of air filter		
Able to identify air filter		

**SESSION - 4: CHANGING OF FUEL FILTER**

**Relevant Knowledge**

Changing a vehicle's fuel filter is a regular part of normal maintenance. Dirt in the fuel is captured in the filter and over time clogs the filter, causing it to operate less efficiently. The clogged filter reduces fuel pressure to the vehicle. Replace the filter at the manufacturer's recommended interval.

**Material and tools requirement for the changing of fuel filter**

- Safety glasses or some other sort of eye protection
- Replacement filter
- Screwdriver to undo clamps
- Container to catch fuel that leaks from hoses
- Rags to clean up any spilled fuel, dispose of them if used



- ❖ Specialty tools, Some vehicles require the use of special tools to disconnect fuel fittings, including the fittings connecting the fuel filter.

These tools should be available at the same parts store from which you purchased your fuel filter.

### Steps

- ❖ Purchase the filter
- ❖ Locate the old filter - it may be in the engine compartment or under the car near the fuel tank
- ❖ If recommended by manufacturer, follow procedure to remove fuel pressure
- ❖ Unscrew each hose clamp bolt until it nearly comes apart from the nut
- ❖ Push the clamp up the hose
- ❖ Remove the old filter and replace with new filter
- ❖ Run the engine and check for leaks.

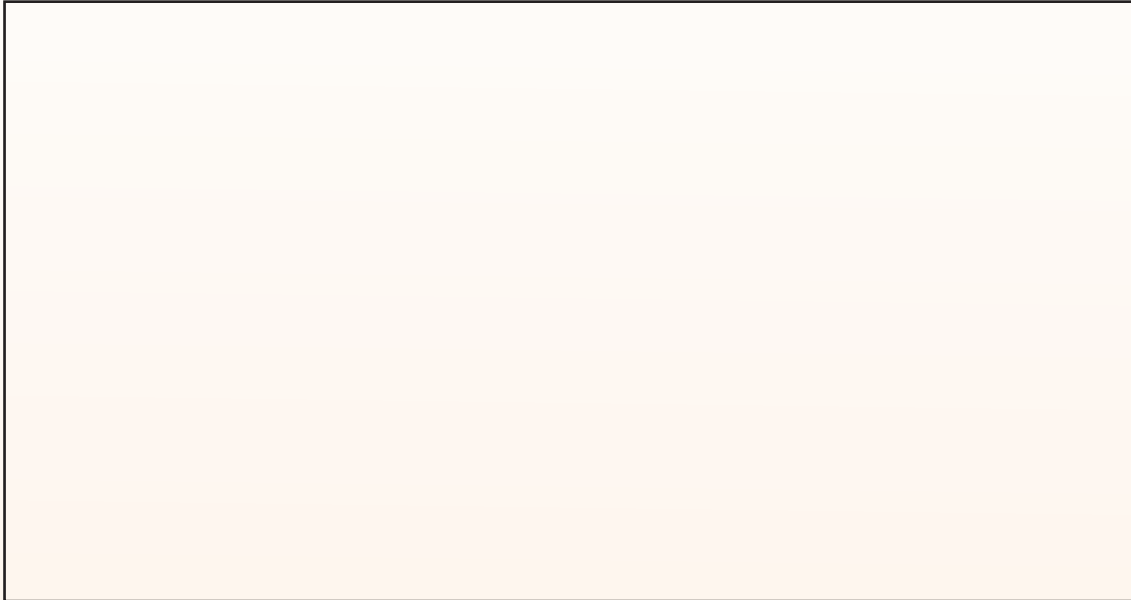


Fig: Photographs of Replacing Fuel Filter



## Exercise: Assignment

1. Prepare a poster showing fuel filter used in a vehicle:



2. Fill in the blanks:

- a) Fuel filter is used for \_\_\_\_\_.
- b) Fuel filter removes \_\_\_\_\_ from fuel.
- c) Clogged filter \_\_\_\_\_ fuel pressure to the vehicle.
- d) Replace the \_\_\_\_\_ at the manufacturer recommended interval.

## Checklist for Assessment Activity

Use the following checklist to see if you've met all the requirements for change of fuel filter.

### Part A

- Share importance of tools used in workshop.

### Part B

Discuss in class the following:

- What is meaning of fuel filter tools?
- What are the different between oil and fuel filter?
- Name two popular tools used in removing fuel filter.

### Performance standards/criteria covered by this assessment

Performance Standards	Yes	No
Able to explain importance of fuel filter		
Able to identify fuel filter		



## SESSION - 5: CHANGING OF COOLANT

### Relevant Knowledge

#### Coolant

A coolant is a fluid which flows through a device to prevent its overheating, transferring the heat produced by the device to other devices that use or dissipate it. An ideal coolant has high thermal capacity, low viscosity, is lowcost, non-toxic, and chemically inert, neither causing nor promoting corrosion of the cooling system. While the term coolant is commonly used in automotive, residential and commercial temperature-control applications, in industrial processing also.

#### Changing of coolant

Most people never change their engine coolant or even know that they should. Whether you call it coolant, antifreeze or radiator fluid, it's the stuff that helps keep your car's engine from overheating, and without it, your car most certainly will overheat quickly and cause massive damage to the engine. To keep your radiator system free of corrosion and performing well keeping your car engine cool; you should change it about every two years. Check your auto's manual for when to change your coolant. While it's a general rule to change vehicle coolant every two years, some manufactures differ on the coolant they use.

#### Material and Tools Requirement for the changing of coolant

##### Coolant

- ❖ Pan
- ❖ Coolant
- ❖ Spanner

##### Steps

1. Purchase the coolant as per manufactures specifications
2. Prepare the vehicle and Keep your car in plain space and keep engine off for few hour so that engine is cool
3. Keep a pan below radiator
4. Open the radiator cap and see level of coolant
5. Open the drain plug nut below radiator chamber by using wrench or by hand if possible
6. Coolant will start coming out and all coolant will be emptied
7. Put back the drain plug at the bottom of radiator
8. Fill the radiator to the top with the coolant
9. Turn the engine on and Let it run for several minutes to get any air out of the system. Watch the temperature gauge to make sure the car does not overheat. After the radiator has burped up air bubbles, turn the car off and carefully fill the radiator to the top with coolant.

Close the radiator cap tightly. Watch the temperature gauge carefully for the next few days.

### Exercise: Assignment

1. Prepare a poster showing coolant being changed in a vehicle:

2. Fill in the blanks:

- a) Coolant is used for \_\_\_\_\_.
- b) Coolant removes \_\_\_\_\_ from engine.
- c) Coolant should be changed at every \_\_\_\_\_ year.
- d) Replace the \_\_\_\_\_ at the manufacturer recommended interval.

### Checklist for Assessment Activity

Use the following checklist to see if you've met all the requirements for coolant change.

#### Part A

- Share the importance of coolant.

#### Part B

Discuss in class the following:

- What is meaning of coolant?
- What is the difference between oil and coolant?
- Name tool used in changing coolant in vehicle.

#### Performance standards/criteria covered by this assessment

Performance Standards	Yes	No
Able to explain importance of coolant		
Able to identify coolant		

## Suggested Reading

### Books

Title	Author	Publisher
Automobile Engineering Vol I	Kirpal Singh	Standard Publishers
Automobile Engineering, Vol II	Kirpal Singh	Standard Publishers
Text Book of Automobile Engineering	R K Rajput	Laxmi Publications
Automobile Engineering	R K Singal	S. K. Kataria and Sons
Automobile Engineering Theory	Kapil Dev	Computech Publications
Automobile Engineering	K. M. Moeed	S. K. Kataria and Sons

### Websites

- ❖ [auto.indiamart.com/auto-technology](http://auto.indiamart.com/auto-technology)
- ❖ [www.automobileindia.com/consumer-guide/automobile-technology](http://www.automobileindia.com/consumer-guide/automobile-technology)
- ❖ [auto.indiamart.com/auto-technology](http://auto.indiamart.com/auto-technology)
- ❖ [books.google.com/books/about/Automobile\\_Engineering.html](http://books.google.com/books/about/Automobile_Engineering.html)
- ❖ [www.bikeadvice.org](http://www.bikeadvice.org)
- ❖ [www.wikipedia.com](http://www.wikipedia.com)
- ❖ [www.shell.com/home/content/ind/products\\_services/on\\_the\\_road](http://www.shell.com/home/content/ind/products_services/on_the_road)

### List of Contributors

1. Mr. Sunil K. Chaturvedi, CEO, Automotive Skills Development Council, Core 4-B 5<sup>th</sup> Floor India Habitat Centre, Lodhi Road, New Delhi - 110 003.
2. Mr. A.C. Deb, Sr. Lecturer, (Auto) - HOD, PUSA Polytechnic PUSA, New Delhi -110012.
3. Mr. Vikas Gautam, S.B.V. NO.1, Morigate, Delhi - 110006.
4. Prof. A. P. Verma, Ex-Prof. & HOD, PSSCIVE, Bhopal.
5. Sh. Deepak Shudhalwar, Assistant Professor, E & T Division, PSSCIVE, Bhopal.
6. Dr. Saurabh Prakash, Associate Professor, E & T Division, PSSCIVE, Bhopal - Programme Coordinator.

# Unit-4

## Customer Sales Care

### Introduction

As you know that vehicles are sold through automobile sales outlets. These outlets are dealers of car/vehicle manufacturer. All vehicle manufacturers sell their product through these dealers. In our country, all automobile companies have a network of vehicle dealers.

Similarly for vehicle maintenance and servicing, service centre have been established by these vehicle dealers. These dealers hire deploy number of employees for sales and marketing of the vehicles. As the customer is the most important for the automobile sector, whenever a customer visits a dealership or service centre of a vehicle manufacturer, it is expected that he/she will be well attended by the company representatives. The role of the sales or marketing representatives is very important. The industry requires a large number of trained manpower for marketing and selling their products.

In this Unit, you will develop an understanding of the role and duties of sales persons employed in the company and its dealerships.

### SESSION - 1: CUSTOMER SERVICE

#### Relevant Knowledge

When a customer visits a vehicle dealership/service centre, a company representative should attend the customer and provide all the information. It can then be said that customer service is in place.

We can say that customer service is a series of activities designed to enhance the level of customer satisfaction – that is, the feeling that a product or service has met the customer expectation before, during and after a purchase.

Customer support is a range of services provided to assist the customers in purchase or maintenance of their vehicles. It includes assistance in planning, installation, training, trouble shooting, maintenance, upgrading, and disposal of a vehicle.

#### Important aspects of a customer service

One of the most important aspects of customer service is that of what is often referred to as the Feel Good Factor. Basically the goal is to not only help the customers have a good experience, but to offer them an experience that exceeds their expectations. Several key points are listed as follows:

1. **Know your product** : Know what products/service you are offering. In other words, be an information expert. It is okay to say 'I don't know', but it should always be followed up by "but let me find out" or possibly "but my friend knows!" Whatever the situation may be, make sure that you don't leave your customer with an unanswered question.

2. **Body Language/Communication:** Most of the communication that we relay to others is done through our body language. If we have a negative body language when we interact with others it can show our lack of care. Two of the most important aspects of positive body language are smiling and eye contact. Make sure to look your customers in the eye. It shows that we are listening to them. And then of course, smiling makes the conversion more positive.
3. **Anticipate Guest Needs:** Nothing surprises your customer more than an employee going the extra mile to help them. Always look for ways to serve your customer in more ways than they expect. In doing so it helps them to know that you care and it will leave them with the "Feel Good Factor" that we are searching for.

### Automobile Sales Person

The automobile sales person is a very important person in the sale and marketing of a vehicle. It is expected that a set of duties will be performed by this person.

- ❖ Sells/leases and delivers a minimum number of vehicle per month (target given by shop owner).
- ❖ Approaches, greets and offers assistance or direction to any customer who enters the dealership.
- ❖ Assists customers in selecting a vehicle by asking questions and listening carefully to their responses.
- ❖ Explains fully the product performance, application and benefits.
- ❖ Describes all optional equipment available for customer purchase.
- ❖ Offers test drives to all prospects.
- ❖ Follows dealership procedure to obtain proper identification from customer prior to test drive.
- ❖ Utilizes dealership sales control and follow-up system.
- ❖ Exhibits high level of commitment to customer satisfaction.
- ❖ Knows and understands the central, state and local laws which govern retail automobile sales.
- ❖ Establishes personal income goals that are consistent with dealership standards of productivity and devises a strategy to meets those goals.
- ❖ Attends product and sales training courses as requested by sales manager.
- ❖ Keeps abreast of new products, features, accessories, etc., and their benefits to customers.
- ❖ Knows and understands equity and values, and is able to explain depreciation to the customer.
- ❖ Ensures that the sales manager has an opportunity to meet each customer.

- ❖ Turns 100 percent of closed deals to finance and insurance manager, along with properly completed paperwork (insurance information, trade title, etc.).
- ❖ Writes complete sales orders and processes paperwork in accordance with established dealership policies.
- ❖ Prepares sold vehicles for customer delivery prior to customer arrival.
- ❖ Delivers vehicles to customers, ensuring that the customer understands the vehicle's operating features, warranty, and paperwork.
- ❖ Introduces customers to service department personnel to emphasize to them the quality and efficiency of service repairs and maintenance available in the dealership's service department.
- ❖ Schedules first service appointment.
- ❖ Follows up on all post delivery items, tag/title work, "we-owes", and special requests to be sure that all customer expectations are met.
- ❖ Maintains an owner follow-up system that encourages repeat and referral business and contributes to customer satisfaction.
- ❖ Maintains a prospect development system.
- ❖ Reviews and analyzes actions at the end of each day, week, month, and year to determine how to better utilize time and plans more effectively.
- ❖ Attends sales meetings.
- ❖ Maintains a well groomed and professional appearance.

These points should be understood and followed by the sales personnels. They will be helpful in performing their duties. A story of successful sales man is given here, student should try to understand the moral of the story.

"In one of the leading consumer electronic sale shop at Delhi, a customer entered in the shop and started shouting that the shop had supplied a defective piece of radio . This radio was not working. Hearing his loud voice, Senior Sales Manager Mr. John came to him and asked what the problem was? The customer started shouting again saying that the shop have given him wrong piece, which was not working. He was asking for a replacement, as it was the policy of the shop to return a piece within 30 days if customer is not satisfied. Mr. John told the customer that he agrees with him, but would like to check the radio first, to which the customer agreed. He checked the radio and found that battery of the radio was fitted in the reverse direction. He fitted battery properly and the radio started working properly.

John offered the customer one set of extra battery. Customer was very happy and he purchased two additional set of battery for himself. Customer thanked the manager for giving him due attention. After 20 day the same customer came to the shop with his nephew and introduced to Mr. John and told that he was in safe hand. His nephew purchased electronic items worth Rs.5 Lakh for his home. Good relationship with customers ensured a good sale for the outlet.

## Exercise: Assignment

1. List the duties performed by automobile sales person:

S.No.	Duties of a Sales Person

2. Prepare a poster showing salesperson in vehicle dealership selling a car:

3. Fill in the blanks:

- a) One of the most important aspects of a customer service is that of what is often referred to as the \_\_\_\_\_.
- b) Know what \_\_\_\_\_ you are offering back to front.
- c) Vehicle are sold at \_\_\_\_\_ by \_\_\_\_\_.
- d) Sales person should greet customer with a smiling \_\_\_\_\_.

### Checklist for Assessment Activity

Use the following checklist to see if you've met all the requirements for pollution control.

#### Part A

- ❖ Share the importance of Customer Service.

#### Part B

Discuss in class the following:

- ❖ Why customer service is necessary in automobile dealerships/service centre?
- ❖ What are important aspects of a customer service?
- ❖ Important duties of sales person in automobile dealerships/service centre?



## Performance standards/criteria covered by this assessment

Performance Standards	Yes	No
Able to explain important aspects of customer service		
Able to discuss important duties of sales person in an automobile dealerships/service centre.		

## Suggested Reading

### Books

Title	Author	Publisher
Automobile Engineering Vol I	Kirpal Singh	Standard Publishers
Automobile Engineering, Vol II	Kirpal Singh	Standard Publishers
Text Book of Automobile Engineering	R K Rajput	Laxmi Publications
Automobile Engineering	R K Singal	S. K. Kataria and Sons
Automobile Engineering Theory	Kapil Dev	Computech Publications
Automobile Engineering	K. M. Moeed	S. K. Kataria and Sons

### Websites

- auto.indiamart.com/auto-technology
- www.automobileindia.com/consumer-guide/automobile-technology
- auto.indiamart.com/auto-technology
- books.google.com/books/about/Automobile\_Engineering.html
- www.bikeadvice.org
- www.wikipedia.com

### List of Contributors

1. Mr. Sunil K. Chaturvedi, CEO, Automotive Skills Development Council, Core 4-B 5<sup>th</sup> Floor India Habitat Centre, Lodhi Road, New Delhi - 110 003.
2. Mr. A.C. Deb, Sr. Lecturer, (Auto) - HOD, PUSA Polytechnic PUSA, New Delhi - 110012.
3. Mr. Vikas Gautam, S.B.V. NO.1, Morigate, Delhi - 110006.
4. Prof. A. P. Verma, Ex-Prof. & HOD, PSSCIVE, Bhopal.
5. Sh. Deepak Shudhalwar, Assistant Professor, E & T Division, PSSCIVE, Bhopal.
6. Dr. Saurabh Prakash, Associate Professor, E & T Division, PSSCIVE, Bhopal - Programme Coordinator.

# Unit-5

## Innovation and Development

### Introduction

As you know whenever there is a demand of any item, then innovation takes place. Innovation leads to development of a technology. With the development of new technologies, the customers get benefits in term of comfort and safety. Sometimes, innovations also results in lowering costs. The Automobile sector is also witnessing lot of innovations and development due to which new automobile models are being launched in the market.

Innovation has also been seen in the field of passenger safety. A number of devices are now provided in the cars so that in case of any accident air bags come into the operation to save the passenger. There is a lot of research going on in the area of alternative fuels due to economic and environmental concern. Even solar energy based cars have been designed these days. And these cars can go up to 80 km in a day. Some cars have been designed to use electrical energy. A combination of electrical and petrol energy have been used in cars called 'hybrid' cars. Technological developments of design and innovation and chassis have led to the development of MPFI system which gives more mileage per liter of fuel.

In earlier times innovations happened less by planning and more by chance. However, in recent decades innovation processes have become more predictable. It is a detailed method for achieving objectives of better designs, lower costs, different fuels etc. In major auto companies of the world there are large teams working on new developments and innovations. It is a continuous process involving lots of experimentation. Very highly qualified engineers and scientists work on such projects. In this Unit, you will develop an understanding of the new innovation and development taking place these days.

### SESSION - 1: INNOVATION AND DEVELOPMENT

#### Relevant Knowledge

#### How innovation takes place?

You must have seen new innovations and developments taking place day by day. New models of four and two wheeler are coming in the market with new design. You may think why it is happening and how these developments takes place. There are many reasons for the developments of innovations, One reason is fierce market place competition. Company R&D is a highly valuable intellectual property and so engineers work under top-secret security as the first company to come to market with a new technology can gain market share. Now let us try to observe and understand how innovation happens in the auto industry.

**It can take 5-10 years or more to bring advanced technologies to market. That's why companies are planning now for 2017.**

➡ It all starts with an idea...followed by years of research, computer simulations, product

development, laboratory testing, road testing, durability trials, consumer testing, certification and more.

- Today's high-tech automobile is 3,000 parts all performing specialized functions in carefully specified ways. So before any auto technology goes on sale, it must pass through a series of advanced test facilities operated by thousands of auto engineers and scientists.
- An auto must function in the harshest climate conditions, from freezing cold to 100% humidity to desert temperatures...running on the roughest roads, from urban potholes to unpaved country roads. Performing at highway speeds...for as much as a 150,000-mile lifetime...while meeting thousands of regulatory standards.

**An automobile purchased today is the product of years of ongoing R & D and investments.**

- Innovations requires lead-time. Bringing a new model to market typically requires 5-7 years in laboratories, proving grounds and production facilities, while a brand new technology takes longer.
- Innovation requires large investments. Developing a new power train typically costs \$1 billion over 5-8 years. That's one reason why manufacturers traditionally rank at the top of R & D funding lists for all industries, including computers and pharmaceuticals.

**The automobile has very high quality control standards compared to other high tech industries.**

- The useful life of consumer electronics is typically 3-5 years, compared to 15+ years for autos.
- Microprocessors in autos must withstand temperature swings from -40 degrees to 130 degrees--double the temperature specs for consumer electronics.

**Meeting the test of time is a huge challenge. Your car performs multiple complex tasks in less than the blink of any eye, but researchers must spend years making a vehicle able to operate within seconds.**

- When it comes to safety, speed is critical. Autos operate in "milliseconds," or thousands of seconds. Front airbags have about 30 milliseconds to sense an impact, analyze incoming data (from brakes or the steering wheel), decide whether to deploy the airbags - and at what level - and inflate in time to shield occupants. Side airbags deploy three times faster.
- Every few milliseconds, the engine control computer must decide how much fuel to inject into the engine and when to ignite the spark plug in order to optimize fuel economy and minimize emissions, and all this occurs while the driver is directing the vehicle to perform in different ways, such as accelerating onto a highway.

**Crash testing helps make vehicles safer through months of different tests and analysis.**

- A crash test may only take two-fifths of a second, but the computer sensors can generate a stream of 4,000 data sets...and engineers need many weeks to analyze all that information.

- ❖ In an auto test facility, a new model of vehicle undergoes testing for about 30 different crash conditions, including side impact, front impact and more.
- ❖ As many as 25 crash test dummies may be used for testing just one model. Each high-tech dummy, which typically costs \$100,000, is wired with sensors connected to a computer.

**Testing in advanced weather facilities is needed to gauge performance under extreme conditions.**

- ❖ Testing centres have built high-tech test chambers so engineers can evaluate products in different environments, ranging from -40F degrees to 130F degrees.
- ❖ Researchers test vehicle performance in special facilities built to mimic monsoon rains and windstorms.
- ❖ A model may spend 200 hours in a wind tunnel as researchers and stylists work to lower wind resistance and improve mileage.

Aerodynamic drag accounts for about 20% of the energy a vehicle needs just to move through normal air resistance.

**Durability testing is important to ensure vehicles meet tough consumer use.**

- ❖ Even the seats are tested for durability. Using robots, automakers research how people of all shapes and sizes affect the upholstery, seat cushions and seat structures over the life of the vehicle.
- ❖ High performance extends to car doors too. It takes 84,000 open-and close cycles to simulate 10 years of customer use on a car door. This testing happens in a wide range of temperatures, just like real life.
- ❖ Manufacturers test and perfect their products at huge, company-owned proving grounds, which include roads designed to replicate real-world conditions...with potholes, bumps and all.

**Despite the fastest computers and sophisticated test chambers, a model still needs to be tested in the real world.**

- ❖ Many operations of a vehicle can be simulated by computer, but engineers need to understand how different systems in an auto interact, and often that can only be done through actual use.
- ❖ To test for durability, an automaker can easily rack up 2 million miles of on-road and track testing on a single model of vehicle. That equates to 80 trips around the world.
- ❖ It's a global industry, and testing is worldwide too. A model may be driven in extreme conditions like the jungles of Brazil and the mountains of New Zealand. Research in the southern hemisphere for tests can extend the seasons for testing and help speed up development.

**As one of the most regulated products in the marketplace, the automobile undergoes rigorous processes to become certified according to engineering and regulatory standards.**

- Through the Society of Automotive Engineers (SAE), 14,000 mobility experts in 100+ countries have provided data resulting in more than 2,600 globally recognized standards for motor vehicle transport.
- An auto must meet more than 200 government safety and environmental regulations in the U.S. alone. Title 40 of the Code of Federal Regulations, which is the section addressing environment, is actually longer than the U.S. tax code.
- Substantial changes to the federal law on occupant crash protection (FMVSS 208) added 50 tests to the auto development cycle, including new crash tests, new test dummies and new airbag requirements. Results from any one of these tests can require vehicle changes, from simple recalibrations to significant re-design and re-testing.
- The road to market can be long. An auto must meet exacting specifications over a long series of tests. If a model doesn't perform as expected on test #37, it may need to be re-engineered...and go back to test #1.

#### **In a way, our assembly lines cover the entire country.**

- Often, innovation is the result of collaboration among automakers, diverse suppliers from many industries, universities and federal labs.
- Automakers depend on more than 30,000 suppliers based in all 50 states. Changes to a model can impact many suppliers and their production processes.
- Lead-time is needed in production, too. Process quality control is a priority, because an automotive product needs to be built the same way every time, from all levels of the supply base through to the assembly facility.

#### **So you must have understood how tedious is to develop a new model**

### **Top 10 Innovations**

The automobile has gone through many innovations, ranging from radios to fuel injection. But what are the top 10 innovations in recent times? Going back 30-ish years, here's what we've come up with:

#### **1. Antilock brakes**

**Time frame:** While there were some electronic braking systems as far back as the 1960s, Mercedes-Benz was reportedly the first to install ABS on production cars, in '78.

**The innovation:** They help maintain control while stopping, as well as throw the door open to stability control and roll mitigation technologies.

**What we did before:** Purists will say "stopped in less distance," but "plowed into objects when the steering locked up" is more accurate.

**Which cars have them:** Most models offer ABS.

#### **2. Airbag advancements**

**Time frame:** The first cars with airbags debuted in the early '70s, Chrysler was the first to make them standard in cars, in 1988.





Fig: Side curtain airbags in the Mercedes-Benz S-Class.

**The innovation:** Airbags have graduated from things that simply blast out of the dashboard to more advanced devices that protect you in a rollover, cushion your knee and adjust for smaller drivers. They can also determine the severity of the impact, your seat position and whether you're wearing a seat belt.

**What we did before:** Relied on seat belts, if we wore them, to protect us.

**Which cars have them:** All cars must have front airbags.

### 3. Key fobs



Fig: Chevrolet Malibu key fob.

**Time frame:** Chevy's '93 Corvette featured General Motors' first Passive Keyless Entry system.

**The innovation:** Fobs now unlock doors, set off the horn and lights if you lose the car in the MegaMart parking lot and, in some cases, mean you don't have to use a key at all. The latest systems can be programmed to remember how you like your seat and mirror and adjust them accordingly. We should be driving jet cars by now. Failing that, not having to fumble with keys, seats and mirrors will have to do fumble with keys, seats and mirrors will have to do.

**What we did before:** Expended needless mental energy remembering where we parked and exhausted ourselves by unlocking doors manually.

**Which cars have them:** Most do.

#### 4. Fold-flat rear seats



*Fig: Fold-flat seats in the Honda Odyssey*

**Time frame:** The first folding rear seats debuted in the '60s, but Honda's foldaway seats in the late-90s Odyssey, later adopted by several automakers, took the concept to a new level.

**The innovation:** Seats that tuck out of the way are so much easier to deal with than those that have to be removed.

**What we did before:** Searched for a place in the garage to stow our van's seats then risked a hernia by removing the heavy, awkward things.

**Which cars have them:** Most sedans have fold-down rear seats, most of the best-selling mini vans have the fold-flat third row.

#### 5. Electronic stability systems

**Time frame:** BMW and Mercedes-Benz introduced them in '95 models.

**The innovation:** A computerized system that applies the car's brakes or cuts the throttle, or a little of both, to keep the car going where you want it to.

**What we did before:** Sometimes drove beyond our, or our car's, capabilities.

**Which cars have them:** Many models offer these systems.

#### 6. DVD players



*Fig: Saturn Vue DVD screen*

**Time frame:** Honda and Saturn first offered them as options in 2002 models.

**The innovation:** They shrunk the DVD player and TV you had in the family room and stuck it in a vehicle. What's so innovative about that? If you have to ask, you must do not have kids.

**What we did before:** Hated life.

**Which cars have them:** Many minivans, wagons and SUVs have them as an option; some cars do as well.

## 7. Heated and cooled seats

**Time frame:** Heated seats have been around for a while, but cooled seats debuted in the mid-90s.

**The innovation:** Electric coils warm the seat, air circulates to cool it.

**What we did before:** Froze ourselves or walked around with sweaty, slimy grimy shirts plastered to our backs.

**Which cars have them:** Many cars offer heated seats. Cars with cooled seats include the Audi A8, BMW 760, 750 and M5, Bentley Continental Flying Spur, Buick Lucerne, Cadillac DTS, Escalade, STS, XLR and DTS, Ford Expedition and GT, Infiniti M35 and M45, Lexus ES, GS, IS and LS, Lincoln LS, Navigator and MKZ, Maserati Quattroporte, Maybach 57 and 62, Mercedes-Benz S, SL, CL, CLK, CLS, E and SLR, Mercury Monterey, Saab 9-5, Toyota Avalon, and VW Phaeton.

## 8. Tilt/telescoping steering wheels and adjustable pedals

**Time frame:** Tilt steering wheels have been around for a long time, but telescoping steering wheels and adjustable pedals only became common in the last 10 years.

**The innovation:** You need to sit at least 10 inches from airbags to avoid injury when they deploy, but shorter folks sometimes can't easily reach the car's controls if they do that.

**What we did before:** Sat too close to the airbag, hurt our backs with bad posture and generally were uncomfortable, and possibly unsafe, behind the wheel.

**Which cars have them:** Many offer them as an option.

## 9. Navigation systems



Fig: Lincoln navigation screen.



**Time frame:** There are debates over who was first, but Honda claims the first nav system, in the 1990 Acura Legend.

**The innovation:** Going beyond paper maps, these systems can act as a copilot, telling you where to go and recalibrating themselves if you miss a turn.

**What we did before:** Refused to ask for directions.

**Which cars have them:** Many offer them as an option.

## 10. Hybrid drive trains

**Time frame:** While electric cars go back to the early days of the automobile, Honda's Insight was the first mass-produced hybrid sold in the U.S., in the 2000 model year.

**The innovation:** Hybrid drive trains combine gas engines with electric motors for power. While some systems are tuned to deliver more performance, the real news is in going farther on a gallon of gas ... and being able to drive a partially electric car without plugging it in.

**What we did before:** Plugged in our electric cars, or bought smaller, lighter vehicles to save gas.

**Which cars have them:** Many offer them as an option.

## Five New Innovations in Car Safety Technologies

Our cars are becoming chicer, more fuel efficient and safer every day, as car manufacturers search for ways to satisfy our desire for the best and the safest.

Today's vehicle effortlessly blend comfort, performance and safety, thereby offering car buyers more than they've ever had before in terms of features and styling. Cutting-edge safety technology has also grown by leaps and bounds, especially over the past few years. Technology continues to produce the best safety features that are designed to protect ourselves, our passengers and other motorists and pedestrians.

### Top five best new innovations in cars safety technology:

1. **Tyre pressure monitoring systems:** Tyre pressure monitoring systems provide the latest and greatest technology for eliminating low tyre pressure on our cars, which can result in an accident or simply poor gas mileage. A tire pressure monitoring system can also alert us in seconds to a flat tyre, thereby reducing the chances of becoming involved in a car accident due to a flat tyre.
2. **Blind-spot detection:** Finally! There now is a system for alerting us if we attempt to make a turn and an object or car is in our blind spot. This technology responds as soon as the driver puts on the turn signal, thereby preventing a collision caused by the driver's blind spot.
3. **Rollover prevention:** Most of the newer SUVs are equipped with electronic stability control systems, but rollover prevention systems take the concept one step

"If you are making a turn too fast and the car senses a potential rollover, the rollover prevention system will apply the brakes and modulate the throttle as needed to help you maintain control of the vehicle."

further. If you are making a turn too fast and the car senses a potential rollover, the rollover prevention system will apply the brakes and modulate the throttle as needed to help you maintain control of the vehicle. Ford calls it Roll Stability Control, while GM calls it Proactive Roll Avoidance.

- 4. Sensitive air bag systems:** In older model cars, the airbag deploys when a front-end crash occurs. However, many of today's vehicles come equipped with more sensitive air bag systems, which sense the difference in the size and weight of the occupants and deploys the air bags accordingly. This technology may even be able to detect that an individual is not wearing a seat belt or that he or she is positioned abnormally in the seat and compensate the air bag deployment to accommodate this.
- 5. Night vision assist:** Properly operating a vehicle takes on a whole new meaning during the night time hours. Some of the newest vehicle technology allows drivers to see further down the road, courtesy thermal-imaging cameras, thereby allowing them to spot animals, pedestrians and other vehicles that they normally would not have seen.

These cutting-edge safety technologies will offer drivers not only added safety when behind the wheel, but may also offer them discounts on their car insurance. Many car insurance companies will offer drivers of safe vehicles, such as those with newer safety technology, discounts on their car insurance, thereby saving money while at the same time protecting themselves, their passengers, and other motorists and pedestrians. The safety technology of today and tomorrow is far-reaching and impressive, to say the least.

These developments are continuous and helpful to passenger. All the big auto manufacturers have Research and Development centres and contribute large amount of funds towards it. As per a report on R&D spending in 2005, the automotive industry invested EUR 68 billion in research & development. Through 2015, this number will rise to EUR 800 billion. (80000 crore)

### Exercise: Assignment

- 1. List the top ten innovations in the automobile sector:**

S.No.	Name of Innovation
1	
2	
3	
4	
5	
6	
7	
8	
9	
10	

## 2. Fill in the blanks:

- a) Innovations are important for \_\_\_\_\_.
- b) Navigation systems is used for \_\_\_\_\_.
- c) New technology helps in \_\_\_\_\_.
- d) Electronic stability systems help in \_\_\_\_\_.

## Checklist for Assessment Activity

Use the following checklist to see if you've met all the requirements for Assessment Activity.

### Part A

- Differentiate between old and new technology.

### Part B

Discuss in class the following:

- Why vehicle manufacturers invest in Research and Development in for vehicle?
- What are the different types innovations used in automobiles?
- What are advantages of using new innovations?
- How innovation takes place in auto sector.

### Performance standards/criteria covered by this assessment

Performance Standards	Yes	No
Able to understand innovation		
Able to recall new innovations in automobiles		

## Suggested Reading

### Books

Title	Author	Publisher
Automobile Engineering Vol I	Kirpal Singh	Standard Publishers
Automobile Engineering, Vol II	Kirpal Singh	Standard Publishers
Text Book of Automobile Engineering	R K Rajput	Laxmi Publications
Automobile Engineering	R K Singal	S. K. Kataria and Sons
Automobile Engineering Theory	Kapil Dev	Computech Publications
Automobile Engineering	K. M. Moeed	S. K. Kataria and Sons

### Websites

- [auto.indiamart.com/auto-technology](http://auto.indiamart.com/auto-technology)
- [www.automobileindia.com/consumer-guide/automobile-technology](http://www.automobileindia.com/consumer-guide/automobile-technology)

- ❖ [auto.indiamart.com/auto-technology](http://auto.indiamart.com/auto-technology)
- ❖ [books.google.com/books/about/Automobile\\_Engineering.html](http://books.google.com/books/about/Automobile_Engineering.html)
- ❖ [www.bikeadvice.org](http://www.bikeadvice.org)
- ❖ [www.wikipedia.com](http://www.wikipedia.com)

### List of Contributors

1. Mr. Sunil K. Chaturvedi, CEO, Automotive Skills Development Council, Core 4-B 5<sup>th</sup> Floor India Habitat Centre, Lodhi Road, New Delhi - 110 003.
2. Mr. A.C. Deb, Sr. Lecturer, (Auto) - HOD, PUSA Polytechnic PUSA, New Delhi - 110012.
3. Mr. Vikas Gautam, S.B.V. NO.1, Morigate, Delhi - 110006.
4. Prof. A. P. Verma, Ex-Prof. & HOD, PSSCIVE, Bhopal.
5. Sh. Deepak Shudhalwar, Assistant Professor, E & T Division, PSSCIVE, Bhopal.
6. Dr. Saurabh Prakash, Associate Professor, E & T Division, PSSCIVE, Bhopal - Programme Coordinator.







## **CENTRAL BOARD OF SECONDARY EDUCATION**

Shiksha Kendra, 2, Community Centre, Preet Vihar, Delhi-110301

Tel: 011-22527183 • Fax: 011-22526580

E-mail: [voc.cbse@gmail.com](mailto:voc.cbse@gmail.com) • Website: [www.cbsevocational.in](http://www.cbsevocational.in)